

Motor Valve 8035

GS 1 series, DN 15 up to DN 150 Version NR2 with safety spring return

Technical Information

Body design	Flangeless, wafer-type construction Dimensions acc. DIN EN 558-1 series 20 for flanges acc. DIN EN 1092-1 form B more versions see data-sheet 8035-GS3	
Nominal sizes	DN 15 up to DN 150	
Nominal pressure (acc. DIN 2401)	PN 40 also for flanges PN 10 up to PN 25	
Fluid temperature	C-steel 1.0570: stainless steel 1.4571:	-10°C up to +350°C -60°C up to +350°C
Ambient temperature	0°C up to +50°C	
Rangeability	30 : 1	
Leakage (% of Kvs)	Disc pair Carbon-stainless steel < 0,0001	Disc pair STN 2 < 0,001
IEC 60534-4 EN 12266-1	IV-S1 E	IV F
Packing leakage	tested according to TA-Luft as defined in DIN EN ISO 15848-1 and VDI 2440	

* With DN15 with reduction of less than 25%, different leakage rates possible.
K_{vs}-values see data sheet 8001.

Technical Information Motor Actuator

Actuating force	1,2 kN	3,0 kN
Type of duty acc. VDE 0530 with control electronics	S 4 - 30% ED	S 4 - 30% ED
without control electronics	S 1 - 100 % ED	S 1 - 100 % ED
Net connections	24 V AC 110 V/120 V AC 230 V AC	24 V AC 110 V/120 V AC 230 V AC
Mounting position	motor not top-down	motor not top-down
Protection class	IP 54 (IP65 optional)	IP 54 (IP65 optional)
Power consumption 24V	21 W	21 W
Power consumption 230V	21 W	21 W
Power consumption 110 V/120 V	21 W	21 W
Stroking time at line break	2,9 - 3,5 sec.	2,9 - 3,5 sec.
Manual operation	by push buttons (electrical power required)	

Materials

Body	C-Steel 1.0570 /1.0619	Stainless steel 1.4581 or 1.4408
Bodycover	C-Steel 1.0570	Stainless steel 1.4571 or 1.4404
Packing	PTFE, carbon filled (spring 1.4310)	
Actuator stem	stainless steel 1.4571, roller burnished	
Fixed valve plate	stainless steel, plated	STN-disc
Sliding disc	special carbon material	STN-disc

Motor Valve 8035-GS1



with safety spring return

Stroking Times

DN	Stroking times (sec.) with stroking speed	
	17,5 mm/min	3,4 mm/min
15	21	110
20	21	110
25	21	110
32	21	110
40	21	110
50	28	146
65	28	146
80	28	146
100	30	154
125	30	154
150	30	154

Options

	actuating force	
	1,2 kN	3 kN
limit switches	max. 2	max. 2
potentiometer	max. 2*	max. 2*
positioner (analogue)	yes	yes

* one potentiometer is required for positioner operation

Admissible Differential Pressure (For temperatures of up to 120°C)

**For temperatures of 120°C and above:
obey application limits !**

DN	1,2 kN	3,0 kN	1,2 kN	3,0 kN
	max. differential pressure (bar)			
	sliding combination			
	carbon - stainless steel		STN 2	
15	40	40	40	40
20	40	40	40	40
25	40	40	40	40
32	40	40	32	40
40	40	40	22	27
50	31	40	13	35
65	26	40	11	29
80	17	40	6,5	17
100	10	25	4	10
125	7	16	2,5	7
150	5	14	2	5

Applications limits for GS1-Valves made of stainless steel

PN 40

DN	Sliding unit: carbon/SFC - stainless steel, coated						Sliding unit: carbon - STN2					
	max. admissible pressures for GS1-valves						max. admissible pressures for GS1-valves					
	100°C	150°C	200°C	250°C	300°C	350°C	100°C	150°C	200°C	250°C	300°C	350°C
15 - 25	40	36	31	28	26	24	40	36	31	28	26	24
32	40	36	31	28	26	24	40	36	31	28	25	22
40	40	36	31	28	26	24	26	25	24	19	16	14
50	40	36	31	28	26	24	40	36	31	28	26	24
65	40	36	31	28	26	24	37	35	31	27	22	19
80	40	36	31	28	26	24	22	20	19	16	13	11
100	24	23	22	19	17	16	13	12	12	9	8	6
125	16	15	14	13	11	10	8	8	7	6	5	4
150	16	16	16	16	14	13	10	10	9	7	6	5

Limitation for SFC-sliding discs: 300°C

Motor Valve 8035-GS1



with safety spring return

Ordering Number System

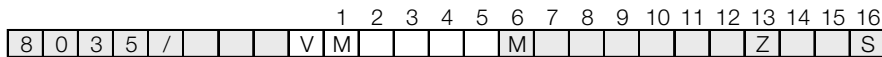

1 - 5 : Please quote all 5 sections.
6 - 12: Quote only if required.

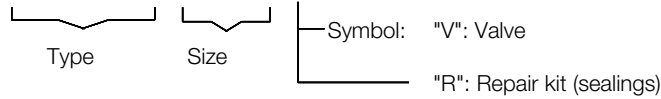

1. Type	2. Connection	3. Body material	4. Safety position	5. Actuator thrust	6. Special versions	7. Voltages	8. Stem sealing
M GS-motor valve safety spring type 8035 (with return)	0 Flangeless design acc. DIN 2632-2635 (PN10-PN40)	0 Carbon steel 1.0619 1 stainless steel 1.4581 or 1.4408	0 Spring closes 1 Spring opens	3 1,2 kN (safety spring return only) 5 3 kN (safety spring return only)	M State, if further sections are quoted	- 230 VAC, 50/60 Hz (standard) 1 24 VAC, 50 Hz 8 120V, 60Hz	- PTFE-packing, self adjusting (standard) 1 Additional bellow 1.4571

9. Moving disc	10. Fixed plate	11. Kvs-values	12. Characte-	13. Accessories	14. Limit switches	15. Feedback	16. Special versions
- Carbon material 9 STN2-disc	- Stainless steel 1.4571, coated 1 STN2-plate	- 100% (Stand.) A red. to 63% 1 red. to 40% B red. to 25% 2 red. to 16% C red. to 10% 3 red. to 6,3% 4 red. to 2,5% 5 red. to 1% 6 red. to 20% 7 red. to 12% 8 red. to 2% 9 red. to 0,4 %	- linear 1 equal percentage	Z Accessories	- none 1 1 stroke dependent limit 2 2 stroke dependent limit switches	- without 1 Potentiometer 1000 Ohm	S Further special versions

17. Stroking speed	18.	19. Positioner
- 17,5 mm/min. 5 3,4 mm/min	- here without significance	- without 3 positioner 0 - 10 V M positioner 0 - 20 mA N positioner 4 - 20 mA

Ordering Example: 8035/050VM0113M- - - - -Z- -S5-3
 GS-motor valve type 8035 with safety spring return, DN 50, PN 10/40, body material stain-
 less steel 1.4571, spring to close, actuator 1.2 kN, 230 V, 50 Hz, PTFE-V-shaped seal,
 carbon material, stainless steel 1.4581, Kvs-value 100 %, Flow characteristic linear, actuator
 speed 3,4 mm/min. , positioner 0-10 V

Motor Valve 8035-GS1

with safety spring return

Dimensions and Weights

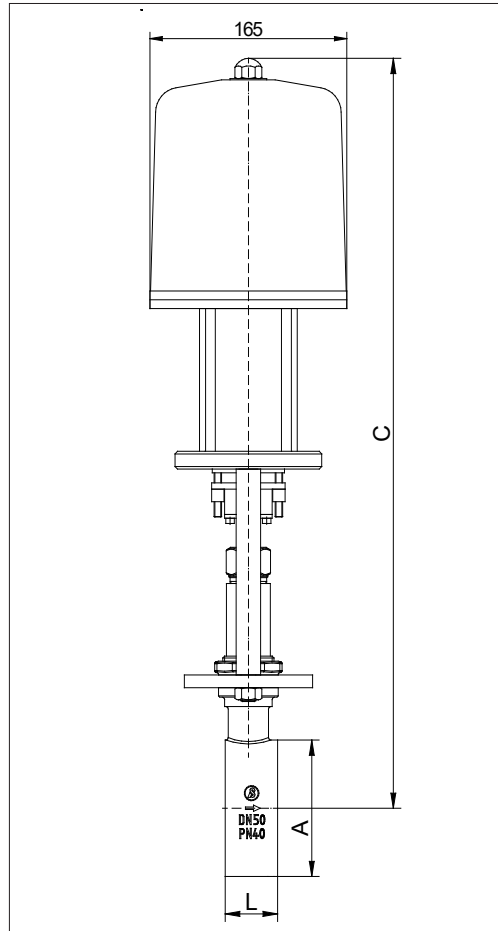

DN	ØA	C* 1.2 kN	C* 3.0 kN	L	weight kg	stroke
15	53	580	598	33	11,6	6
20	62	585	603	33	11,7	6
25	72	590	608	33	11,8	6
32	82	595	613	33	11,9	6
40	92	600	618	33	12	6
50	108	610	628	43	13,1	8
65	127	620	638	46	13,6	8
80	142	625	643	46	14,3	8
100	164	640	658	52	15,5	8,5
125	194	655	673	56	17,3	8,5
150	219	670	688	56	19,3	8,5

* For the motor actuator with integrated positioner C increases for 40 mm.

Dimensions in mm