

Pinch Valve for endless tubes 7072

DN 6 up to DN 14



Pinch valve for special applications in chemistry, foodstuff industry and dispensary.

- Fast and simple change of tube
- Change the fixing-pieces for using tubes from DN6 to DN14 (for tube diameters 10 to 18 mm)
- No room for dirt, easy to sterilize by steam
- Pneumatic actuator
- No fluid contact to the valve

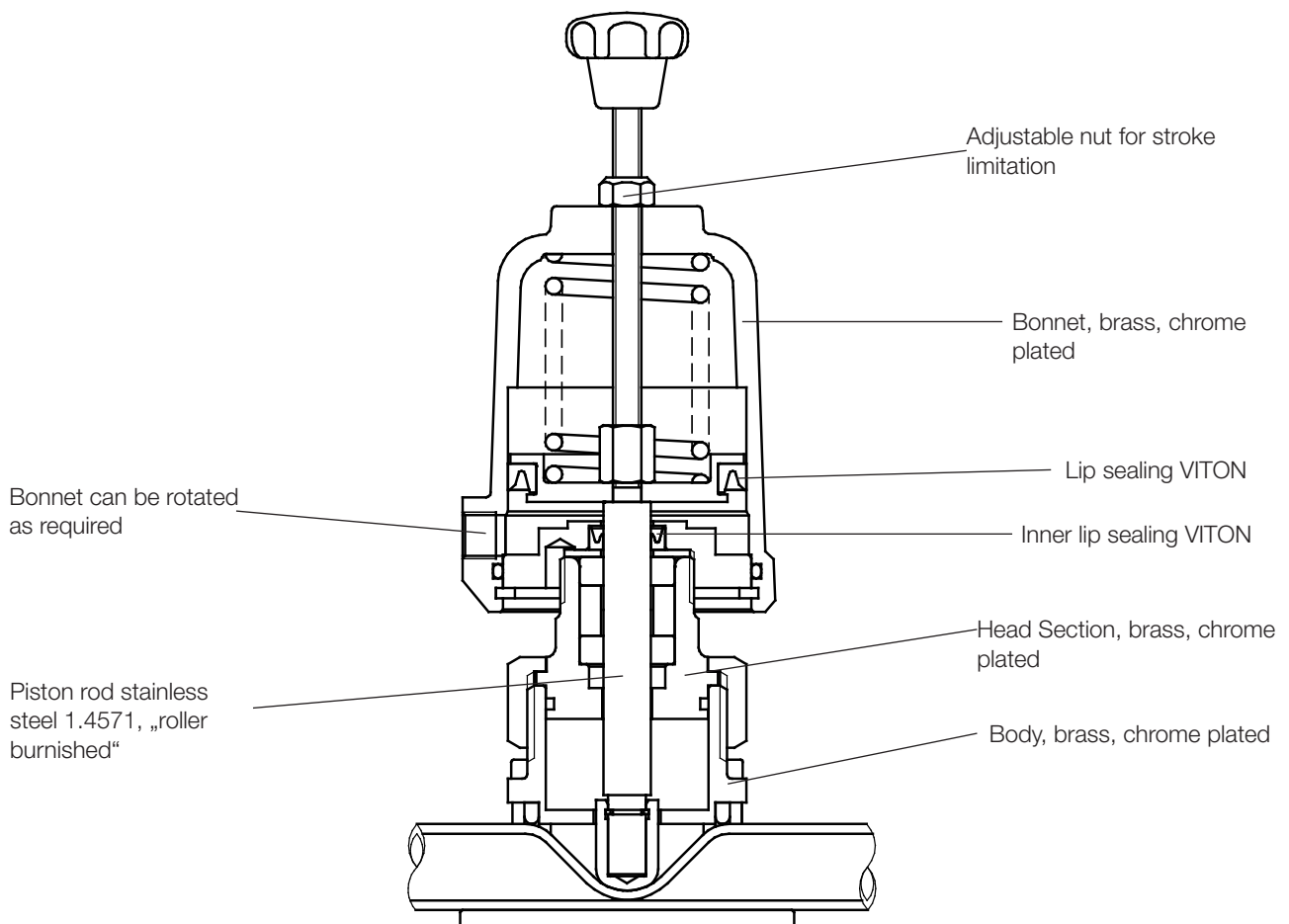

Technical Information

Tube (inner diameter)	DN 6 - 8 - 10 - 12 - 14
Tube (outer diameter)	10 - 12 - 14 - 16 - 18 mm
3 interchangeable fixing pieces	10 - 14 - 18 mm
Body material	brass, chrome plated
Working pressure	0 - 4 bar (according to the quality of the tube, the shore hardness and the thickness of the tube material)
Tube types	all types of elastomer up to shore hardness 65°A
Pilot pressure	2.5 - 10 bar
Thread for pilot connection	G 1/8"
Fluid temperature	-30°C up to +170°C (according to the quality of the tube)
Ambient temperature	-30°C up to +60°C
Viscosity of fluid	up to 0,001 m ² /s (1000cSt, 132°E)
Weight	1.6 kg

Dimensions

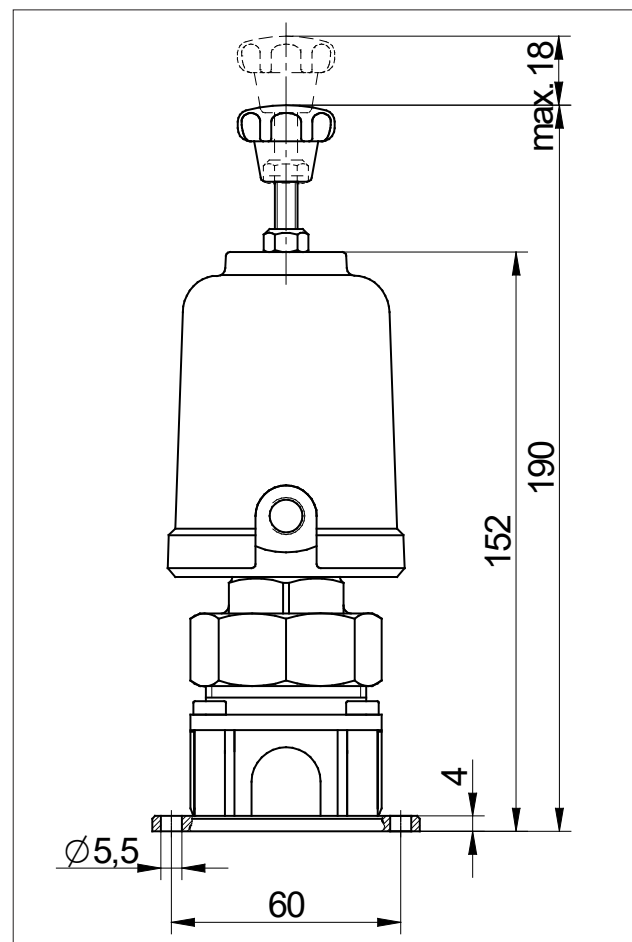
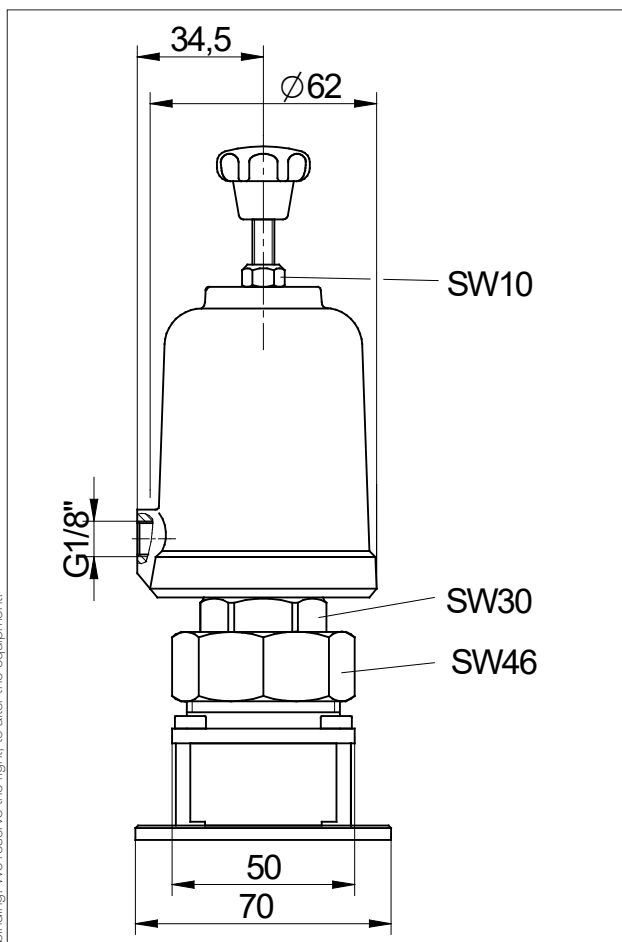

Text and pictures are not binding. We reserve the right, to alter the equipment.