

GS 3 series - DN 15 up to DN 250

Pneumatic sliding gate valve for shutting off liquid and gaseous media for industrial applications

- Space saving wafer-type construction
- Lowest possible weight (especially in larger sizes)
- Low operation noise level
- Control of high differential pressures with small actuators
- Greatly reduced energy consumption rates due to short strokes and low actuating force
- High Kvs-values
- Meets the requirements of TA-Luft 2021



Technical Information

Design	wafer-type design for flanges acc. DIN EN 1092-1 Form B or ASME B16.5 RF further versions see data sheet 8040/41-GS1		
Nominal size	DN 15 up to DN 250		
Nominal pressure acc. DIN 2401 for flanges with facing type B	PN 40 (fits also to PN 10-25) PN 16 und PN25	DN 15 - DN 150	DN 200 - DN 250
Nominal pressure acc. ANSI for flanges acc. ASME B16.5 RF	ANSI 150 ANSI 300	DN 15 - DN 250 DN 15 - DN 150	
Nominal pressure acc. JIS for „raised face“ flanges	10K 20K	DN 15 - DN 50 DN 15 - DN 40	
Media temperature	Versions from -60°C up to +350°C		
Ambient temperature*	-15°C up to +60°C (sepcial versions from -40°C up to +100°C)		
Flange gaskets (customer side)	DIN EN 1514-1 or ANSI B16.21 in the respective nominal pressure rating		
Pilot pressure	maximum 10 bar (higher on demand)		
Leakage (% of Kvs) EN 12266-1	disc pair carbon-stainless steel < 0,0001 E	disc pair SFC < 0,0005 F	disc pair STN 2 < 0,001 F
Marking ATEX non electric	II 2G Ex h IIC T6...T1 X Gb II 2D Ex h IIC 85°C...350°C X Db		
Spezific leakage rate shaft and body sealing	ISO FE-BH-CC3-SSA0-t(-40°C/+350°C)-PN40-ISO 15848-1		

* With DN15 with reduction of less than 25%, different leakage rates possible.
K_{vs}-values see data sheet 8001.

Fluid temperature

Rating	PN40	PN 16	PN 100	ANSI 150	ANSI 300	ANSI 600
Body material cpl. stainless steel						
Tmin [°C]	-60	-60	-60	-29	-29	-29
Tmax [°C]	350	350	350	350	350	350
Body material carbon steel with stainless steel body cover						
Tmin [°C]	-60	-60	-10	-20	-20	-20
Tmax [°C]	350	350	350	350	350	350
Body material Alloy C-276						
Tmin [°C]	-60	-60	-60	-29	-29	-29
Tmax [°C]	350	350	350	350	350	350

Sliding Gate Valve 8040-GS3

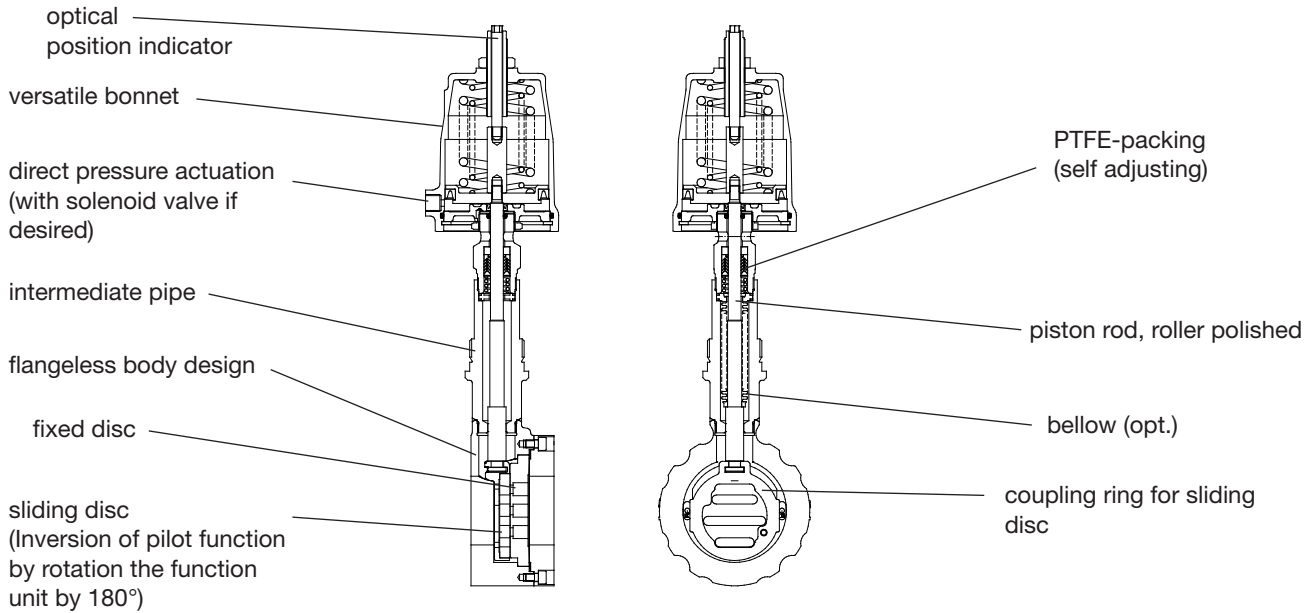

Materials

Body	stainless steel 1.4408	carbon steel 1.0619
Bodycover	stainless steel 1.4571 or 1.4404	
Bonnet	brass plated (actuator ø 50 mm, ø 80 mm) aluminium corrosion proof (actuator ø 125 mm)	
Springs	stainless steel 1.4301 (actuator ø 50 mm, ø 80 mm) spring steel wire C, coated (actuator ø 125 mm)	
Packing	PTFE carbon filled (spring 1.4310)	
Valve stem	stainless steel 1.4571, roller burnished	
Bellow	stainless steel 1.4571	
Fixed plate	stainless steel 1.4571, plated	STN2-disc
Sliding disc	standard: special carbon material	SFC-disc STN2-disc
Coupling ring for disc	stainless steel 1.4581	

Admissible differential pressures (For temperatures of up to 120°C)

For temperatures of 120°C and above: obey application limits !

Disc pair carbon/SFC - stainless steel				STN2-disc pair			
DN	actuator	max. working pressure (bar)	required pilot pressure (bar)	DN	actuator	max. working pressure (bar)	required pilot pressure (bar)
15	50	33,2	3,7	15	50	23,6	3,7
20	50	28,8	3,7	20	50	18,2	4
25	50	24,2	3,7	25	50	13,6	4,4
32	50	19,8	3,8	32	50	10,1	4,6
40	50	15	4,2	40	50	6,9	4,9
50	50	9,8	4,8	50	50	4,1	5,3
65	50	8,3	5	65	50	3,4	5,4
80	50	5,3	5,2	80	50	2,1	5,5
100	50	3,4	5,4	100	50	1,3	5,6
125	50	2,3	5,5	125	50	-	-
150	50	1,7	5,6	150	50	-	-
15	80	51,1	3	15	80	51,1	3
20	80	51,1	3	20	80	48,6	3,3
25	80	51,1	3	25	80	36,3	3,7
32	80	51,1	3,1	32	80	27	4
40	80	40,1	3,6	40	80	18,6	4,2
50	80	26,3	4,1	50	80	11,1	4,6
65	80	22,1	4,2	65	80	9,1	4,6
80	80	14,1	4,5	80	80	5,5	4,7
100	80	9	4,7	100	80	3,4	4,8
125	80	6,1	4,8	125	80	2,3	4,9
150	80	4,6	4,8	150	80	1,7	4,9
200	80	2,6	4,9	200	80	0,9	5
250	125	1,6	5	250	80	0,5	5
15	125	51,1	1,7	15	125	51,1	1,7
20	125	51,1	1,7	20	125	51,1	1,9
25	125	51,1	1,7	25	125	51,1	2,1
32	125	51,1	1,8	32	125	39,6	2,3
40	125	51,1	2	40	125	27,2	2,4
50	125	38,6	2,3	50	125	16,3	2,6
65	125	32,5	2,4	65	125	13,3	2,6
80	125	20,6	2,6	80	125	8,1	2,7
100	125	13,2	2,7	100	125	5	2,8
125	125	9	2,7	125	125	3,3	2,8
150	125	6,7	2,7	150	125	2,5	2,8
200	125	3,9	2,8	200	125	1,4	2,8
250	125	2,3	2,8	250	125	0,8	2,9

	Upper limits for admissible pressures in bar					
	PN16	PN40	PN100	ANSI150	ANSI 300	ANSI 600
P max. carbon steel	16	40	100	19,6	51,1	102,1
P max. stainless steel				19,0	49,6	99,3

Ordering Number System

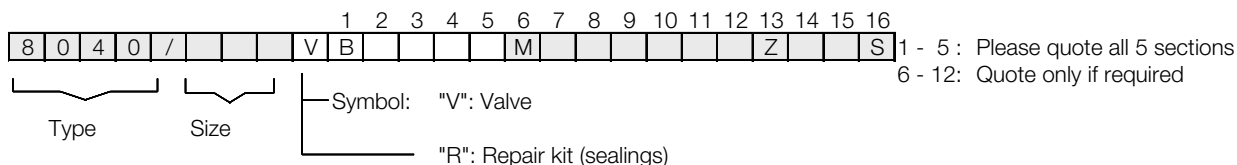

1.	Type	2.	Connection	3.	Body material	4.	Safety position	5.	Actuator	6.	Special versions
B	Sliding gate valve, long design (type 8040)	E	GS3-flangeless design acc. ANSI 150	0	carbon steel 1.0619	0	spring closes	0	piston 50 mm	M	State, if further sections are quoted groove and groove acc. DIN EN1092-1 groove and tongue acc. DIN EN1092-1 2x lowered face acc. DIN EN1092-1 lowered and raised face acc. DIN EN1092-1
		F	GS3-flangeless design acc. ANSI 300	1	stainless steel 1.4408	1	spring opens	1	piston 80 mm	A	
		G	GS3-flangeless design acc. DIN PN16/40	2	carbon steel 1.0619, short version	3	double acting	2	piston 125 mm	C	
				3	stainless steel 1.4408, short version					E	
										H	
7.	Springs	8.	Stem sealing	9.	Moving disc	10.	Fixed plate	11.	Kvs-values	12.	Characteristic
-	standard	-	PTFE-packing, self adjusting (standard)	-	carbon material	-	stainless steel	-	100% (Stand.)	-	linear
1	one spring			9	STN2		1.4581, hard-chrome plated	A	red. to 63%	1	equal
3	three springs	1	additional bellows 1.4571	S	SFC	1	STN2 (only in combination with the position „9“ STN2-disc)	B	red. to 40%		percentage
								C	red. to 25%		
								2	red. to 16%		
								3	red. to 10%		
								4	red. to 6,3%		
								5	red. to 2,5%		
								6	red. to 1%		
								7	red. to 20%		
								8	red. to 12%		
								9	red. to 2%		
									red. to 0,4%		
13.	Accessories	14.	Switches etc.	15.	Pilot valves	16.	Special versions				
Z	accessories	-	without	-	without	S	further special versions				
M	el. position indicator (cable bushing)	1	one micro switch	6	pilot valve 230 VAC						
		2	two micro switches	7	pilot valve 24 VDC						
N	el. position indicator (plug connection)	3	manual operation								
		4	stroke limitation								
		8	two inductive switches 10-36 VDC PNP								
		P	one inductive switch 10-36 VDC PNP								

Ordering example: 8040/050VBG100M-1 - - - -Z-6
 sliding gate valve, long design 8040, DN 50, PN10/40, stainless steel, NC, actuator Ø 50 mm, with bellow, Disc pair: carbon material - stainless steel 1.4571 coated, lineare characteristics 100 %, pilot valve 230 V AC.

Application limitations for GS3 valves in stainless steel

These pressure must not be exceeded for GS-valves from the GS3-series made of stainless steel, even though the actuator power might allow it.

PN40

DN	Sliding unit: carbon/SFC - stainless steel, coated						Sliding unit: STN2					
	max. admissible pressures for GS3-valves in stainless steel						max. admissible pressures for GS3-valves in stainless steel					
	100°C	150°C	200°C	250°C	300°C	350°C	100°C	150°C	200°C	250°C	300°C	350°C
15-32	40	40	40	40	40	40	40	40	40	40	40	40
40	40	40	40	40	40	40	40	40	40	40	40	37
50	40	40	40	40	40	40	40	40	40	40	40	40
65	40	40	40	40	40	40	40	40	40	40	37	32
80	40	40	40	40	40	40	36	34	33	26	22	19
100	33	33	33	33	33	33	32	31	30	24	20	17
125	23	23	23	23	23	23	21	21	19	16	13	11
150	16	16	16	16	16	16	15	15	14	11	9	8
200 (max. PN25)	16	16	15	13	12	11	8	7	6	5	4	3
250 (max. PN25)	10	9	9	8	7	6	5,7	5,4	5,1	4,1	3,4	2,9

Limitation for SFC-sliding discs: 300°C

PN100

DN	Sliding unit: carbon/SFC - stainless steel, coated						Sliding unit: STN2					
	max. admissible pressures for GS3-valves in stainless steel						max. admissible pressures for GS3-valves in stainless steel					
	100°C	150°C	200°C	250°C	300°C	350°C	100°C	150°C	200°C	250°C	300°C	350°C
15	100	100	100	93	84	79	100	100	100	93	84	79
20	100	100	89	81	73	68	100	100	89	81	73	68
25	88	81	70	63	57	54	88	81	70	63	57	54
32	100	93	80	73	65	62	100	93	80	73	65	60
40	88	81	70	63	57	54	72	69	65	53	43	37
50	100	100	100	100	100	94	77	73	70	56	46	40
65	80	80	80	79	71	67	62	59	56	45	37	32
80	48	48	48	48	48	44	36	34	33	26	22	19

Limitation for SFC-sliding discs: 300°C

ANSI150

DN	Sliding unit: carbon/SFC - stainless steel, coated								Sliding unit: STN2							
	max. admissible pressures for GS3-valves in stainless steel								max. admissible pressures for GS3-valves in stainless steel							
	38°C	50°C	100°C	150°C	200°C	250°C	300°C	350°C	38°C	50°C	100°C	150°C	200°C	250°C	300°C	350°C
15-125	19,0	18,4	16,2	14,8	13,7	12,1	10,2	8,4	19,0	18,4	16,2	14,8	13,7	12,1	10,2	8,4
150	16,0	16,0	16,0	14,8	13,7	12,1	10,2	8,4	16,2	16,2	16,2	14,8	13,7	11,8	9,7	8,4
200	16,0	16,0	16,0	14,8	13,7	12,1	10,2	8,4	10,5	10,0	8,3	7,6	6,9	5,5	4,5	3,9
250	10,4	10,4	10,4	9,9	9,4	8,4	7,4	6,8	5,7	5,7	5,7	5,4	5,1	4,1	3,4	2,6

Limitation for SFC-sliding discs: 300°C

ANSI300

DN	Sliding unit: carbon/SFC - stainless steel, coated								Sliding unit: STN2							
	max. admissible pressures for GS3-valves in stainless steel								max. admissible pressures for GS3-valves in stainless steel							
	38°C	50°C	100°C	150°C	200°C	250°C	300°C	350°C	38°C	50°C	100°C	150°C	200°C	250°C	300°C	350°C
15-65	49,6	48,1	42,2	38,5	35,7	33,4	31,6	30,3	49,6	48,1	42,2	38,5	35,7	33,4	31,6	30,3
80	48,0	48,0	42,2	38,5	35,7	33,4	31,6	30,3	36,6	36,6	36,6	34,8	33,0	26,8	22,0	19,0
100	33,0	33,0	33,0	33,0	33,0	33,0	31,6	30,3	33,0	33,0	33,0	31,7	30,1	24,4	20,1	17,3
125	23,0	23,0	23,0	23,0	23,0	23,0	23,0	23,0	22,0	22,0	22,0	21,0	19,9	16,1	13,2	11,5
150	16,0	16,0	16,0	16,0	16,0	16,0	16,0	16,0	16,0	16,0	16,0	15,4	14,6	11,8	9,7	8,4
200	16,0	16,0	16,0	14,8	13,7	12,1	10,2	8,4	10,5	10,0	8,3	7,6	6,9	5,5	4,5	3,9

Limitation for SFC-sliding discs: 300°C

ANSI600

DN	Sliding unit: carbon/SFC - stainless steel, coated								Sliding unit: STN2							
	max. admissible pressures for GS3-valves in stainless steel								max. admissible pressures for GS3-valves in stainless steel							
	38°C	50°C	100°C	150°C	200°C	250°C	300°C	350°C	38°C	50°C	100°C	150°C	200°C	250°C	300°C	350°C
15-20	99,3	96,2	84,4	77,0	71,3	66,8	63,2	60,7	99,3	96,2	84,4	77,0	71,3	66,8	63,2	60,7
25	88,0	88,0	84,4	77,0	70,1	63,7	57,3	54,2	88,0	88,0	84,4	77,0	70,1	63,7	57,3	54,2
32	99,3	96,2	84,4	77,0	71,3	66,8	63,2	60,7	99,3	96,2	84,4	77,0	71,3	66,8	63,2	60,2
40	88,0	88,0	84,4	77,0	70,1	63,7	57,3	54,2	72,5	72,5	72,5	69,0	65,5	53,1	43,6	37,7
50	99,3	96,2	84,4	77,0	71,3	66,8	63,2	60,7	77,7	77,7	77,7	73,9	70,2	56,9	46,7	40,4
65	80,0	80,0	80,0	77,0	71,3	66,8	63,2	60,7	62,5	62,5	41,7	59,5	56,4	45,8	37,6	32,5
80	48,0	48,0	48,0	48,0	48,0	48,0	48,0	44,5	36,6	36,6	36,6	34,8	33,0	26,8	22,0	19,0

Limitation for SFC-sliding discs: 300°C

Application limitations for GS3 valves in carbon steel

These pressure must not be exceeded for GS-valves from the GS3-series made of carbon steel, even though the actuator power might allow it.

PN40

DN	Sliding unit: carbon/SFC - stainless steel, coated						Sliding unit: STN2					
	max. admissible pressures for GS3-valves in carbon steel						max. admissible pressures for GS3-valves in carbon steel					
	100°C	150°C	200°C	250°C	300°C	350°C	100°C	150°C	200°C	250°C	300°C	350°C
15-50	40	40	40	40	40	40	40	40	40	40	40	40
65	40	40	40	40	40	40	40	40	40	37	32	32
80	40	40	40	40	40	40	36	34	33	26	22	19
100	33	33	33	33	33	33	33	31	30	24	20	17
125	23	23	23	23	23	23	22	21	19	16	13	11
150	16	16	16	16	16	16	16	15	14	11	9	8
200 (max PN 25)	16	16	15	13	12	11	8	7	6	5	4	3
250 (max PN 25)	10	9	9	8	7	6	5,7	5,4	5,1	4,1	3,4	2,9

Limitation for SFC-sliding discs: 300°C

PN100

DN	Sliding unit: carbon/SFC - stainless steel, coated						Sliding unit: STN2					
	max. admissible pressures for GS3-valves in carbon steel						max. admissible pressures for GS3-valves in carbon steel					
	100°C	150°C	200°C	250°C	300°C	350°C	100°C	150°C	200°C	250°C	300°C	350°C
15 - 20	100	100	100	100	100	100	100	100	100	100	100	100
25	100	100	100	100	94	87	100	100	100	100	94	87
32	100	100	100	100	100	99	100	100	100	84	69	60
40	100	100	100	100	94	87	72	69	65	53	43	37
50	100	100	100	100	100	94	77	73	70	56	46	40
65	80	80	80	80	80	76	62	59	56	45	37	32
80	48	48	48	48	48	44	36	34	33	26	22	19

Limitation for SFC-sliding discs: 300°C

PN16

DN	Sliding unit: carbon/SFC - stainless steel, coated						Sliding unit: STN2					
	max. admissible pressures for GS3-valves in carbon steel						max. admissible pressures for GS3-valves in carbon steel					
	100°C	150°C	200°C	250°C	300°C	350°C	100°C	150°C	200°C	250°C	300°C	350°C
15-100	16	16	16	16	16	16	16	16	16	16	16	16
125	16	16	16	16	16	16	16	16	16	13	11	11
150	16	16	16	16	16	16	16	15	14	11	9	8
200	16	16	15	13	12	11	8	7	6	5	4	3
250	10	9	9	8	7	6	-	-	-	-	-	-

Limitation for SFC-sliding discs: 300°C

ANSI150

DN	Sliding unit: carbon/SFC - stainless steel, coated								Sliding unit: STN2							
	max. admissible pressures for GS3-valves in carbon steel								max. admissible pressures for GS3-valves in carbon steel							
	38°C	50°C	100°C	150°C	200°C	250°C	300°C	350°C	38°C	50°C	100°C	150°C	200°C	250°C	300°C	350°C
15-125	19,6	19,2	17,7	15,8	13,8	12,1	10,2	8,4	19,6	19,2	17,7	15,8	13,8	12,1	10,2	8,4
150	16,0	16,0	16,0	15,8	13,8	12,1	10,2	8,4	16,2	16,2	16,2	15,4	13,8	11,8	9,7	8,0
200	16,0	16,0	16,0	15,8	13,8	12,1	10,2	8,4	10,5	10,0	8,3	7,6	6,9	5,5	4,5	3,9
250	10,5	10,5	10,5	9,9	9,4	8,4	7,4	6,0	-	-	-	-	-	-	-	-

Limitation for SFC-sliding discs: 300°C

ANSI300

DN	Sliding unit: carbon/SFC - stainless steel, coated								Sliding unit: STN2							
	max. admissible pressures for GS3-valves in carbon steel								max. admissible pressures for GS3-valves in carbon steel							
	38°C	50°C	100°C	150°C	200°C	250°C	300°C	350°C	38°C	50°C	100°C	150°C	200°C	250°C	300°C	350°C
15-50	51,1	50,1	46,6	45,1	43,8	41,9	39,8	37,6	51,1	50,1	46,6	45,1	43,8	41,9	39,8	37,6
65	51,1	50,1	46,6	45,1	43,8	41,9	39,8	37,6	41,7	41,7	41,7	39,7	37,6	33,5	37,6	33,0
80	48,0	48,0	46,6	45,1	43,8	41,9	39,8	37,6	36,6	36,6	36,6	34,8	33,0	26,8	22,0	19,0
100	33,0	33,0	33,0	33,0	33,0	33,0	33,0	33,0	33,0	33,0	33,0	31,7	30,1	24,4	20,0	17,5
125	23,0	23,0	23,0	23,0	23,0	23,0	23,0	23,0	22,1	22,1	22,1	21,0	19,9	16,1	13,2	11,5
150	16,0	16,0	16,0	16,0	16,0	16,0	16,0	16,0	16,0	16,0	16,0	15,4	14,6	11,8	9,7	8,4
200	16,0	16,0	16,0	14,8	13,7	12,1	10,2	8,4	10,5	10,0	8,3	7,6	6,9	5,5	4,5	3,9

Limitation for SFC-sliding discs: 300°C

ANSI600

DN	Sliding unit: carbon/SFC - stainless steel, coated								Sliding unit: STN2							
	max. admissible pressures for GS3-valves in carbon steel								max. admissible pressures for GS3-valves in carbon steel							
	38°C	50°C	100°C	150°C	200°C	250°C	300°C	350°C	38°C	50°C	100°C	150°C	200°C	250°C	300°C	350°C
15-25	102,1	100,2	93,2	90,2	87,6	83,9	79,6	75,1	102,1	100,2	93,2	90,2	87,6	83,9	79,6	75,1
32	102,1	100,2	93,2	90,2	87,6	83,9	79,6	75,1	102,1	100,2	93,2	90,2	87,6	83,9	69,6	60,0
40	100,0	100,0	93,2	90,2	87,6	83,9	79,6	75,1	72,5	72,5	72,5	69,0	65,5	53,1	43,6	37,0
50	100,0	100,0	93,2	90,2	87,6	83,9	79,6	75,1	77,7	77,7	77,7	73,9	70,2	56,9	46,7	40,0
65	80,0	80,0	80,0	80,0	80,0	80,0	79,6	75,1	62,5	62,5	62,5	59,5	56,4	45,8	37,6	32,0
80	48,0	48,0	48,0	48,0	48,0	48,0	48,0	44,0	36,6	36,6	36,6	36,8	33,0	26,8	22,0	19,0

Limitation for SFC-sliding discs: 300°C

Dimensions and Weights

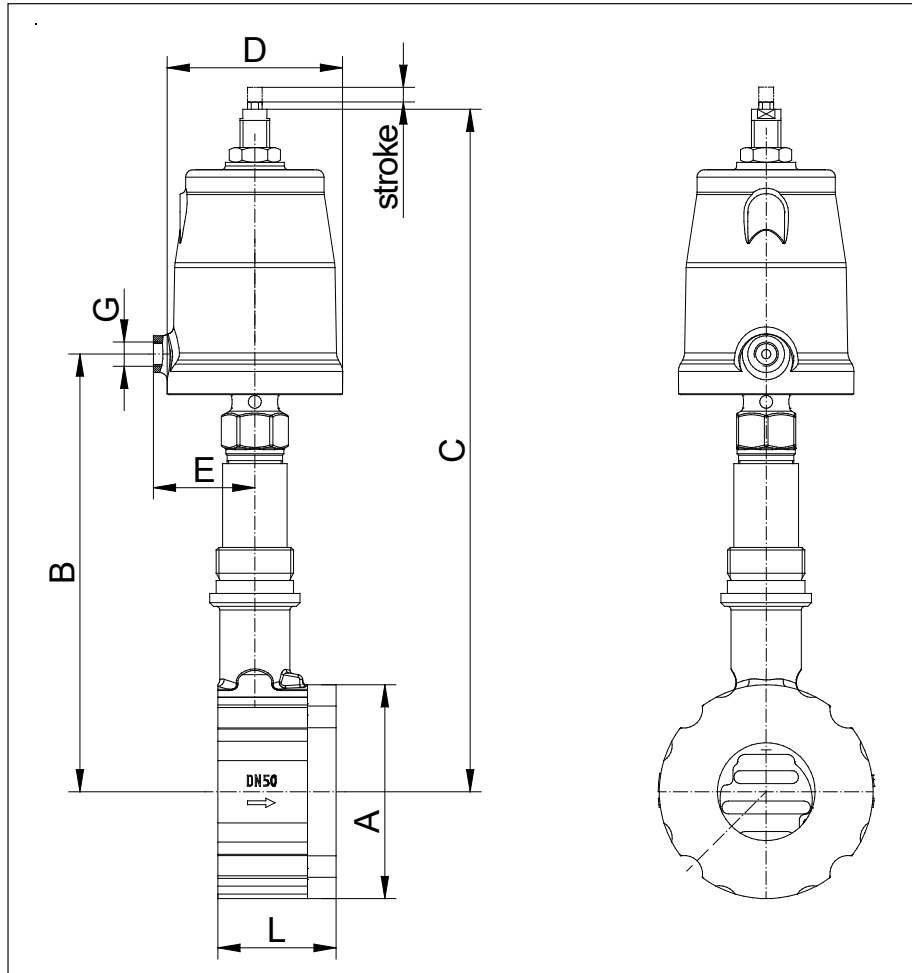

DN	A	B actuator			C max actuator			L	Weight kg actuator			Stroke H
		50	80	125	50	80	125		50	80	125	
15	64	209	213	215	306	344	362	56	3,4	5,6	7	6
20	72	213	217	219	310	348	366	56	3,6	5,8	7,2	6
25	82	218	222	224	315	353	371	56	3,9	6,1	7,5	6
32	89	220	224	226	317	355	373	56	4,1	6,3	7,7	6
40	99	226	230	232	323	361	379	56	4,4	6,6	8	6
50	116	234	238	240	333	371	389	64	5,9	8,1	9,5	8
65	138	243	247	249	342	380	398	68	7,4	9,6	11	8
80	153	252	256	258	351	389	407	70	8,6	11	12	8
100	184	265	269	271	364	402	420	75	12	14	15	8,5
125	212	279	283	285	378	416	434	80	14	16	18	8,5
150	242	292	296	298	391	429	447	80	18	20	22	8,5
200	302	320	324	326	419	457	475	93	35	37	38	8,5

Dimension C „reduced design“ shortened by 25,4 mm Dimensions in mm

Actuator mm	D	G	E
50	62	1/8"	34,5
80	96	1/4"	55
125	146	1/4"	80

Dimensions in mm