

Sliding Gate Valve 8621

GS3 series - DN 15 up to DN 200

Pneumatic sliding gate flange valve optionally with integrated positioner for regulating and shutting off liquid and gaseous media for industrial applications

- Flange connection acc. to ASME B16.5 in ANSI150 or ANSI300
- Construction in match with the ASME B16.34, API RP 553, API 598, ASME B31.1 (Power Piping) and ASME B31.3 (Process Piping)
- Low energy usage due to small actuating forces for the closing element
- Fast response due to small strokes
- Controllability of high differential pressures with small actuators
- Quiet operation
- High cv-values
- Versions acc. to NACE MR0175, ASME B31.5 (Refrigeration Piping and Heat Transfer Components), ASME B31.8 (Transmission and Distribution Piping Systems) and ASME B31.9 (Building Services Piping) on request



Technical data

Design	flange design acc. ASME B16.5 RF		
Nominal Sizes	DN 15 - 200	Class 150 Class 300	
Fluid Temperature	Stainless steel body Carbon steel body	-60°C up to +350°C -29°C up to +350°C	
Ambient Temperatur	digital positioner -10°C up to +75°C analog positioner -15°C up to +60°C		
Rangeability / Characteristic analog positioner digital positioner	30 : 1 40 : 1 linear / 80 : 1 equal percentage		
Leakage **	Disc pair Carbon-stainless steel	Disc pair SFC	Disc pair STN 2/ STN 3
% of Kvs IEC 60534-4 EN 12266-1	< 0,0001 IV-S1 E	< 0,0005 IV-S1 F	< 0,001 IV F
Spezific leakage rate shaft and body sealing	ISO FE-BH-CC3-SSA0-t(-40°C/+350°C)-PN40-ISO 15848-1		
Marking ATEX non electric	II 2G Ex h IIC T6...T1 X Gb II 2D Ex h IIIC 85°C...530°C X Db		

* Please consider the limitation of use of the positioner!

** With DN15 with reduction of less than 25%, different leakage rates possible.
Kvs-values see data sheet 8001.

Positioner

Please refer to the corresponding data sheets for the technical data of the positioners.

Materials

Stainless steel version			
Valve body	stainless steel, 1.4408 / CF8M		
Endpiece	stainless steel, 1.4408 / CF8M		
Valve stem	stainless steel 1.4571/ 316Ti		
coupling ring	stainless steel 1.4581		
Packing tube	stainless steel 1.4408 / CF8M		
Packing	PTFE carbon filled (spring 1.4310)		
Body seal	Graphite with stainless steel foil		
Fixed disc	stainless steel coated	STN2-disc	STN3-disc
Sliding disc	special carbon material	SFC-disc (max. +300°C)	STN2-disc

carbon steel version			
Valve body	carbon steel, 1.0619 / WCC		
Endpiece	carbon steel, 1.0619 / WCC		
Valve stem	stainless steel 1.4571 / 316Ti		
coupling ring	stainless steel 1.4581		
Packing tube	stainless steel 1.4408 / CF8M		
Packing	PTFE carbon filled (spring 1.4310)		
Body seal	Graphite with stainless steel foil		
Fixed disc	stainless steel coated	STN2-disc	STN3-disc
Sliding disc	special carbon material	SFC-disc (max. +300°C)	STN2-disc

For all versions	
Diaphragm casing	aluminium KTL-coated or stainless steel
Actuator springs	stainless steel 1.4310
Coupling	zinc die-cast or stainless steel
Mounting parts	stainless steel

Sliding Gate Valve 8621



with integrated digital positioner type 8049
(also on-off valves and valves with other side-mounted positioner)

Admissible differential pressures

(For temperatures of up to 38°C)

**For temperatures above 38°C:
obey application limits!**

**Disc pair:
Carbon - stainless steel coated /
SFC - stainless steel coated**

Actuator Size	125 cm ²		250 cm ²			500 cm ²		
Supply air (bar)	4,5	5,5	3,0	4,0	5,7	3,0	4,5	5,1
DN	max. admissible differential pressure (bar)							
15	51,7	51,7	51,7	51,7	51,7	-	-	-
20	51,7	51,7	51,7	51,7	51,7	-	-	-
25	51,7	51,7	51,7	51,7	51,7	-	-	-
40	51,7	51,7	51,7	51,7	51,7	-	-	-
50	44	51,7	51,7	51,7	51,7	51,7	51,7	51,7
80	23	29	40	48	48	48	48	48
100	15	16	25	31	33	33	33	33
150	7	8	13	15	16	16	16	23
200	4	5	7	9	12	15	16	16
Spring Configuration	Code 3 (Standard)	Code 4	Code 3 (Standard)	Code 4	Code 6	Code 6 (Standard)	Code 8	Code B

Standard

**Disc pair:
STN 2 / STN 3**

Actuator size	125 cm ²		250 cm ²			500 cm ²		
Supply air (bar)	4,5	5,5	3,0	4,0	5,7	3,0	4,5	5,4
DN	max. admissible differential pressure (bar)							
15	51,7	51,7	51,7	51,7	51,7	-	-	-
20	51,7	51,7	51,7	51,7	51,7	-	-	-
25	51,7	51,7	51,7	51,7	51,7	51,7	51,7	-
40	31	38	51,7	51,7	51,7	51,7	51,7	-
50	18	22	31	38	51	51,7	51,7	51,7
80	9	10	15	19	25	32	36	37
100	5	6	9	11	16	19	23	30
150	2	3	4	5	8	9	11	15
200	2	2	3	3	4	6	7	8
Spring Configuration	Code 3 (Standard)	Code 4	Code 3 (Standard)	Code 4	Code 6	Code 6 (Standard)	Code 8	Code B

Standard

Upper limits of the pressure rating

	Upper limits for admissible pressures in bar	
	ANSI150	ANSI 300
P max. carbon steel	19,6	51,7
P max. stainless steel	19,0	49,6

Sliding Gate Valve 8621

with integrated p/p-or i/p-positioner, Type 8047

Admissible differential pressures
(For temperatures of up to 38°C)

**For temperatures above 38°C:
obey application limits!**

Disc pair:
Carbon - stainless steel coated /
SFC - stainless steel coated

Actuator size	125 cm ²		250 cm ²		500 cm ²	
Spring range (bar)	1,5 up to 3,0	1,8 up to 3,8	1,2 up to 2,2	1,5 up to 2,7	1,2 up to 2,2	1,5 up to 2,7
Supply air (bar)	4	5	3	4	3	4,5
DN	max. admissible differential pressure (bar)					
15	51,7	51,7	51,7	51,7	-	-
20	51,7	51,7	51,7	51,7	-	-
25	51,7	51,7	51,7	51,7	51,7	51,7
40	29	36	49	51,7	51,7	51,7
50	17	21	29	35	51,7	51,7
80	8	10	14	17	29	35
100	5	6	9	10	18	22
150	2	3	4	5	9	10
200	2	2	3	3	5	6
Spring Configuration	Code 3 (Standard)	Code 4	Code 3 (Standard)	Code 4	Code 3 (Standard)	Code 4

Standard

Disc pair:
STN 2 / STN 3

Actuator Size	125 cm ²		250 cm ²		500 cm ²	
Spring Range (bar)	1,5 to 3,0	1,8 to 3,8	1,2 to 2,2	1,5 to 2,7	1,2 to 2,2	1,5 to 2,7
Supply air (bar)	4	5	3	4	3	4,5
DN	max. admissible differential pressure (bar)					
15	51,7	51,7	51,7	51,7	51,7	51,7
20	37	46	51,7	51,7	51,7	51,7
25	25	31	43	51,7	51,7	51,7
40	11	14	19	24	40	48
50	6	8	11	13	23	27
80	3	4	5	6	11	13
100	2	2	3	4	6	8
150	-	1	2	2	3	4
200	-	-	0,9	1,1	1,8	2,2
Spring Configuration	Code 3 (Standard)	Code 4	Code 3 (Standard)	Code 4	Code 6 (Standard)	Code 6

Standard

Upper limits of the pressure rating

	Upper limits for admissible pressures in bar	
	ANSI150	ANSI 300
P max. carbon steel	19,6	51,7
P max. stainless steel	19,0	49,6

Ordering number system

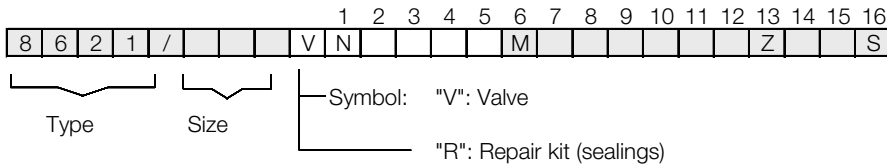

1 - 5 : Please quote all 5 sections.
6 - 12: Quote only if required.

1. Function	2. Body design	3. Body material	4. Safety function	5. Actuator
N	Sliding gate valve with pneumatic actuator	E GS3-flangeless design acc. ASME B16.5 ANSI 150 F GS3-flangeless design acc. ASME B16.5 ANSI 300	0 Carbon steel WCC/1.0619 1 Stainless steel CF8M/1.4408	0 Spring closes 1 Spring opens
6. Special version	7. Springs	8. Steam sealing	9. Moved disc	10. Fixed disc
M	To state, if further sections are quoted	- Standard 4 8 Springs 6 12 Springs B 22 Springs	- PTFE-packing, self adjusting (Standard)	- Carbon material 9 STN2 S SFC
11. Kvs-Values	12. Flow characteristic	13. Accessories	14. Positioner	15. Signaling equipment
- 100 % (Stand.) A red. up to 63 % 1 red. up to 40 % B red. up to 25 % 2 red. up to 16 % C red. up to 10 % 3 red. up to 6,3 % 4 red. up to 2,5 % 5 red. up to 1 % 6 red. up to 20 % 7 red. up to 12 % 8 red. up to 2 % 9 red. up to 0,4 %	- linear 1 equal-%	Z To state if further sections are quoted	- without 1 p/p-positioner Type 8047 3 i/p-positioner Type 8047 6 i/p-positioner type 8047 Eex ib IIC T6 with plug M12x1 8 i/p-positioner + connector M12x1 C dig. positioner, type 8049, 4-wire R dig. positioner, type 8049, 2-wire W dig. positioner, type 8049 ExPro, ATEX, IECEX K dig. positioner, type 8049 ExPro-FM N dig. positioner, type 8049 IO-Link version	- without 0 2 limit switches M12x1 DC 10-30V PNP Y Feedback module RM4 for positioner type 8049 with 2 integrated limit switches acc. Namur (EN60947-5-6) P Feedback module RM5 for positioner type 8049 with 2 integrated limit switches
16. Further versions				
S Other special versions have to be quoted in letters!				

Ordering example: 8621/050VNF106M-----ZC
 sliding gate valve Type 8621, DN 50, flange ANSI Class 300, body material stainless steel, spring closes, actuator 125 cm² NPT, PTFE-packing, moving disc: carbon steel-stainless steel 1.4571 coated, flow characteristic, positioner 8049-4

Application limitations for GS3 valves in stainless steel

These pressure must not be exceeded for GS-valves from the GS3-series made of stainless steel, even though the actuator power might allow it.

ANSI150

DN	Sliding unit: carbon/SFC - stainless steel, coated								Sliding unit: STN2							
	max. admissible pressures for GS3-valves in stainless steel								max. admissible pressures for GS3-valves in stainless steel							
	38°C	50°C	100°C	150°C	200°C	250°C	300°C	350°C	38°C	50°C	100°C	150°C	200°C	250°C	300°C	350°C
15-100	19,0	18,4	16,2	14,8	13,7	12,1	10,2	8,4	19,0	18,4	16,2	14,8	13,7	12,1	10,2	8,4
150	16,0	16,0	16,0	14,8	13,7	12,1	10,2	8,4	16,2	16,2	16,2	14,8	13,7	11,8	9,7	8,4
200	16,0	16,0	16,0	14,8	13,7	12,1	10,2	8,4	10,5	10,0	8,3	7,6	6,9	5,5	4,5	3,9

Limitation for SFC-sliding discs: 300°C

ANSI300

DN	Sliding unit: carbon/SFC - stainless steel, coated								Sliding unit: STN2							
	max. admissible pressures for GS3-valves in stainless steel								max. admissible pressures for GS3-valves in stainless steel							
	38°C	50°C	100°C	150°C	200°C	250°C	300°C	350°C	38°C	50°C	100°C	150°C	200°C	250°C	300°C	350°C
15 - 50	49,6	48,1	42,2	38,5	35,7	33,4	31,6	30,3	49,6	48,1	42,2	38,5	35,7	33,4	31,6	30,3
80	48,0	48,0	42,2	38,5	35,7	33,4	31,6	30,3	36,6	36,6	36,6	34,8	33,0	26,8	22,0	19,0
100	33,0	33,0	33,0	33,0	33,0	33,0	31,6	30,3	33,0	33,0	33,0	31,7	30,1	24,4	20,1	17,3
150	16,0	16,0	16,0	16,0	16,0	16,0	16,0	16,0	16,2	16,2	16,2	14,8	13,7	11,8	9,7	8,4
200	16,0	16,0	16,0	14,8	13,7	12,1	10,2	8,4	10,5	10,0	8,3	7,6	6,9	5,5	4,5	3,9

Limitation for SFC-sliding discs: 300°C

Application limitations for GS3 valves in carbon steel

These pressure must not be exceeded for GS-valves from the GS3-series made of carbon steel, even though the actuator power might allow it.

ANSI150

DN	Sliding unit: carbon/SFC - stainless steel, coated								Sliding unit: STN2							
	max. admissible pressures for GS3-valves in carbon steel								max. admissible pressures for GS3-valves in carbon steel							
	38°C	50°C	100°C	150°C	200°C	250°C	300°C	350°C	38°C	50°C	100°C	150°C	200°C	250°C	300°C	350°C
15-100	19,8	19,5	17,7	15,8	13,8	12,1	10,2	8,4	19,6	19,2	17,7	15,8	13,8	12,1	10,2	8,4
150	16,0	16,0	16,0	15,8	13,8	12,1	10,2	8,4	16,2	16,2	16,2	15,4	13,8	11,8	9,7	8,0
200	16,0	16,0	16,0	14,8	13,7	12,1	10,2	8,4	10,5	10,0	8,3	7,6	6,9	5,5	4,5	3,9

Limitation for SFC-sliding discs: 300°C

ANSI300

DN	Sliding unit: carbon/SFC - stainless steel, coated								Sliding unit: STN2							
	max. admissible pressures for GS3-valves in carbon steel								max. admissible pressures for GS3-valves in carbon steel							
	38°C	50°C	100°C	150°C	200°C	250°C	300°C	350°C	38°C	50°C	100°C	150°C	200°C	250°C	300°C	350°C
15-50	51,7	51,7	51,5	50,2	48,6	46,3	42,9	40,0	51,7	51,7	51,5	50,2	48,6	46,3	42,9	40,0
80	48,0	48,0	46,6	45,1	43,8	41,9	19,8	40,0	36,6	36,6	36,6	34,8	33,0	26,8	22,0	19,0
100	33,0	33,0	33,0	33,0	33,0	33,0	19,8	33,0	33,0	33,0	33,0	31,7	30,1	24,4	20,0	17,0
150	16,0	16,0	16,0	16,0	16,0	16,0	16,0	16,0	16,0	16,0	16,0	15,4	14,6	11,8	9,7	8,0
200	16,0	16,0	16,0	14,8	13,7	12,1	10,2	8,4	10,5	10,0	8,3	7,6	6,9	5,5	4,5	3,9

Limitation for SFC-sliding discs: 300°C

Sliding Gate Valve 8621

with integrated digital positioner type 8049



Dimensions and weights

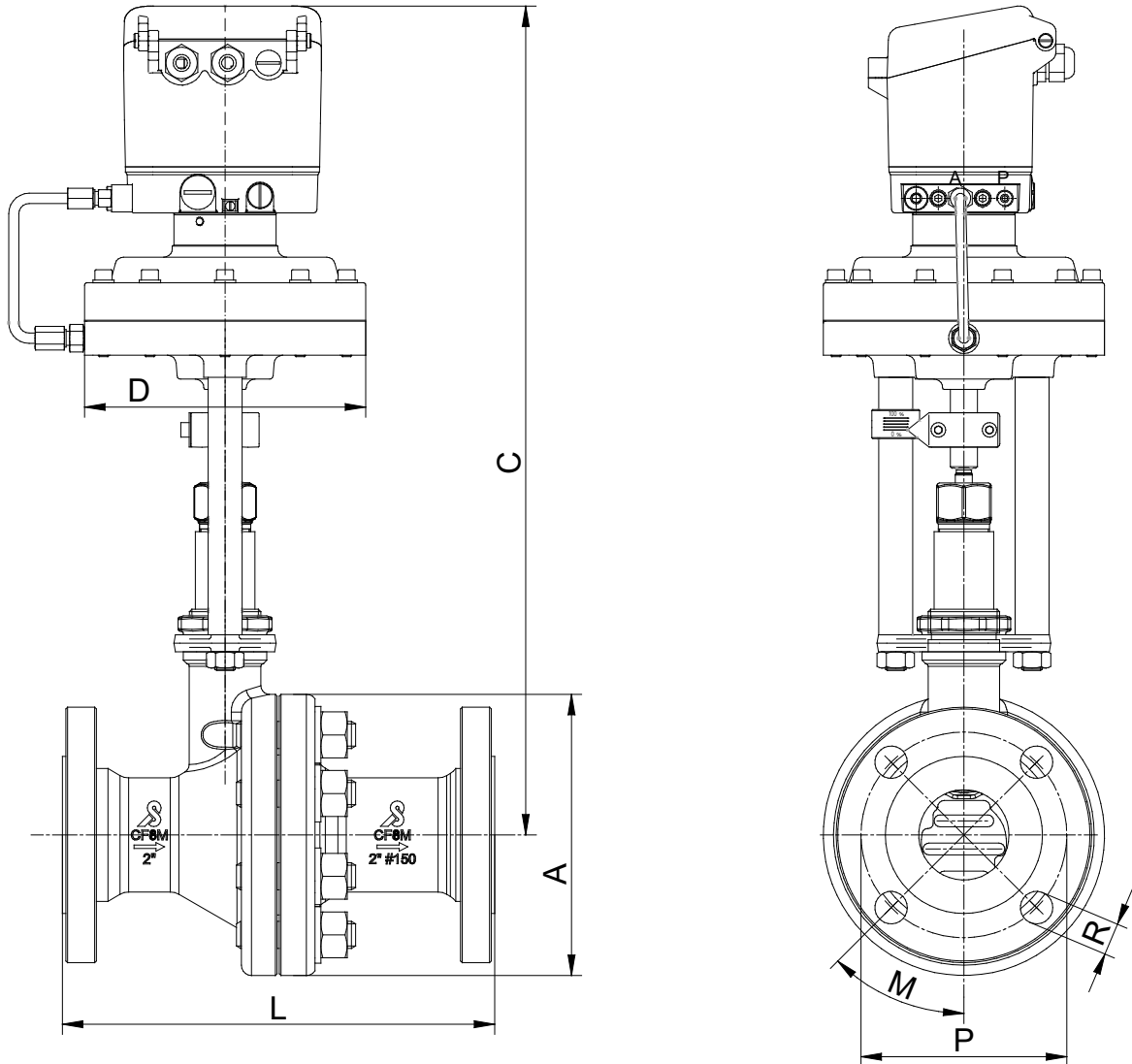

DN	Ø A	ØC actuator size		ØD actuator size		ANSI 150								
		D125/ D250	D500	D 125	D250/ D500	P	M	numbers	L	R	weight (kg)			
											D125	D250	D500	
15	95	460	510	165	222	60,3	45	4	184	15,88	10	12,2	15,9	
20	115	465	515	165	222	69,9	45	4	184	15,88	11,8	14	17,7	
25	125	470	520	165	222	79,4	45	4	184	15,88	13,3	15,5	19,2	
40	155	480	530	165	222	98,4	45	4	222	15,88	17,9	20,1	23,8	
50	165	490	540	165	222	120,7	45	4	254	19,05	20,8	23	26,7	
80	210	510	560	165	222	152,4	45	4	298	19,05	35,1	37,3	41	
100	248	520	570	165	222	190,5	22,5	8	352	19,05	47,9	50,1	53,8	
150	320	550	600	165	222	241,3	22,5	8	451	22,22	79,4	81,6	85,3	
200	380	546	570	165	222	299	15	12	543	25,4	131	134	138	

DN	ANSI 300									stroke
	P	M	numbers	L	R	weight (kg)				
						D125	D250	D500		
15	66,7	45	4	190	15,88	10,4	12,6	16,3	6	
20	82,6	45	4	194	19,05	13	15,2	18,9	6	
25	88,9	45	4	197	19,05	14,4	16,6	20,3	6	
40	114,3	45	4	235	22,22	20,7	22,9	26,6	6	
50	127	22,5	8	267	19,05	22,9	25,1	28,8	8	
80	168,3	22,5	8	318	22,22	39,2	41,4	45,1	8	
100	200	22,5	8	368	22,22	56,5	58,7	62,4	8,5	
150	269,9	15	12	473	22,22	98,4	100,6	104,3	8,5	
200	330	15	12	568	25,4	160	162	166	8,5	

Sliding Gate Valve 8621

with integrated i/p-positioner type 8047

Dimensions and weights

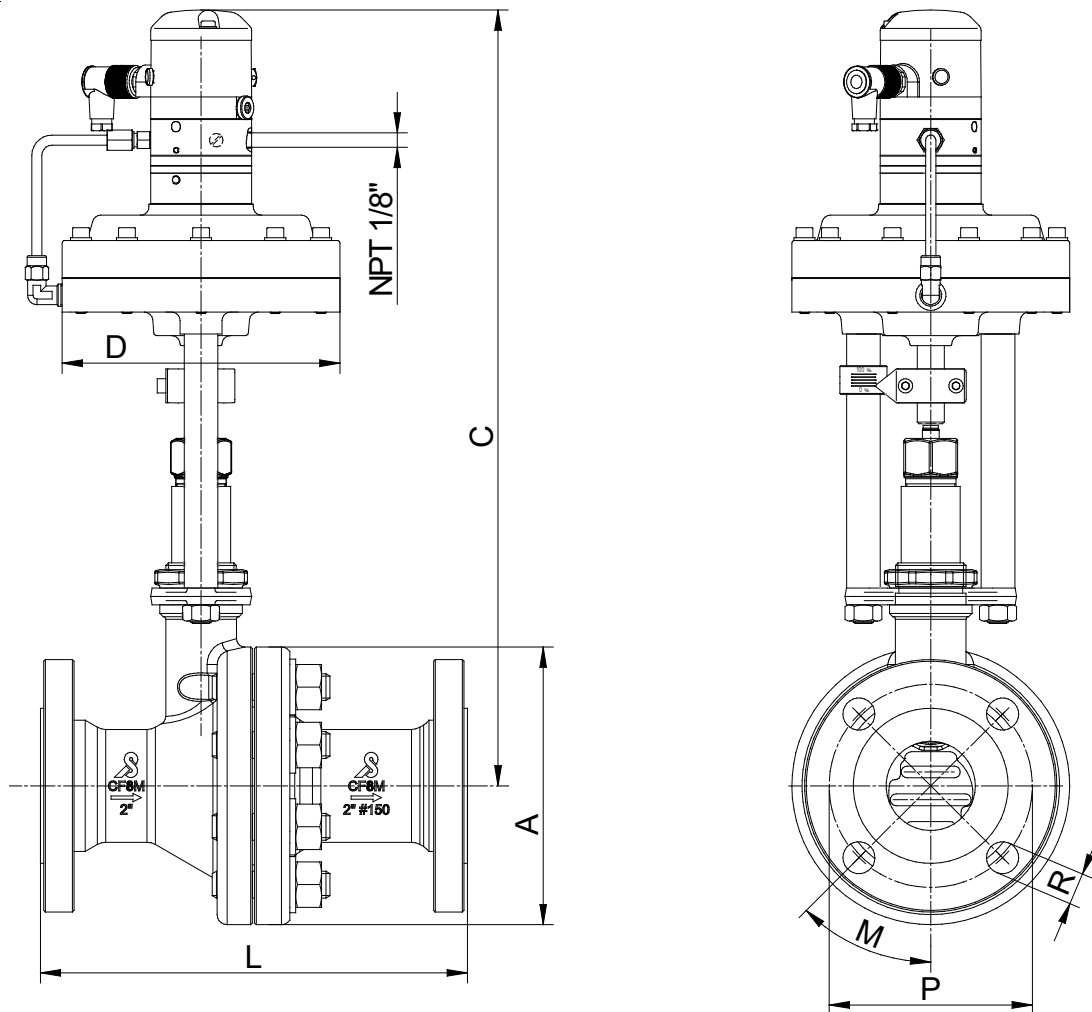

DN	Ø A	ØC actuator size		ØD actuator size		ANSI 150								
		D125/ D250	D500	D 125	D250/ D500	P	M	numbers	L	R	weight (kg)			
											D125	D250	D500	
15	95	430	480	165	222	60,3	45	4	184	15,88	10	12,2	15,9	
20	115	435	485	165	222	69,9	45	4	184	15,88	11,8	14	17,7	
25	125	440	490	165	222	79,4	45	4	184	15,88	13,3	15,5	19,2	
40	155	450	500	165	222	98,4	45	4	222	15,88	17,9	20,1	23,8	
50	165	460	510	165	222	120,7	45	4	254	19,05	20,8	23	26,7	
80	210	480	530	165	222	152,4	45	4	298	19,05	35,1	37,3	41	
100	248	505	555	165	222	190,5	22,5	8	352	19,05	47,9	50,1	53,8	
150	320	520	570	165	222	241,3	22,5	8	451	22,22	79,4	81,6	85,3	
200	380	550	600	165	222	298,5	15	12	543	25,4	131,39	133,59	138	

DN	ANSI 300									stroke
	P	M	numbers	L	R	weight (kg)				
						D125	D250	D500		
15	66,7	45	4	190	15,88	10,4	12,6	16,3	6	
20	82,6	45	4	194	19,05	13	15,2	18,9	6	
25	88,9	45	4	197	19,05	14,4	16,6	20,3	6	
40	114,3	45	4	235	22,22	20,7	22,9	26,6	6	
50	127	22,5	8	267	19,05	22,9	25,1	28,8	8	
80	168,3	22,5	8	318	22,22	39,2	41,4	45,1	8	
100	200	22,5	8	368	22,22	56,5	58,7	62,4	8,5	
150	269,9	15	12	473	22,22	98,4	100,6	104,3	8,5	
200	330,2	15	12	568	25,4	160	162	166	8,5	

Sliding Gate Valve 8621

with integrated p/p-positioner type 8047

Dimensions and weights

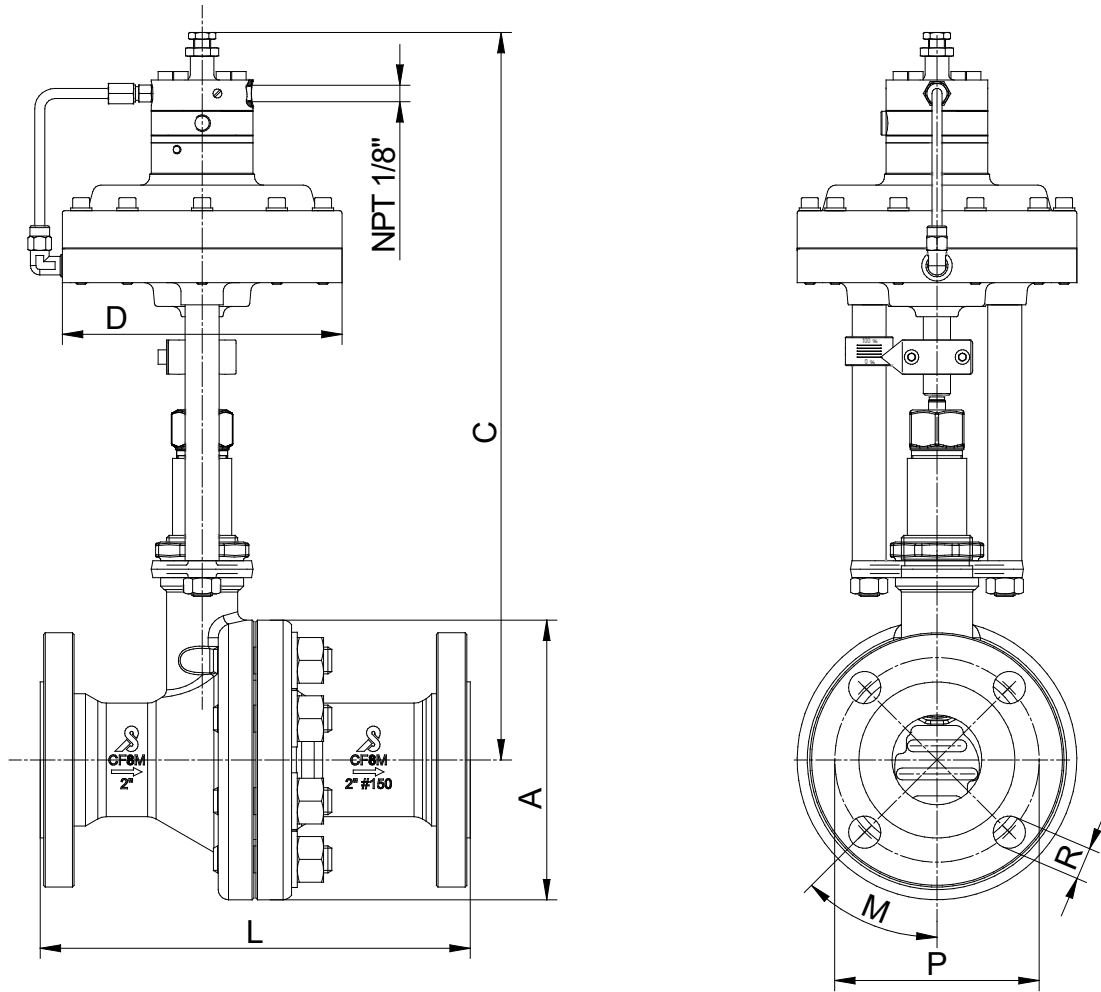

DN	Ø A	ØC		ØD		ANSI 150								
		actuator size		actuator size		P	M	numbers	L	R	weight (kg)			
		D125/ D250	D500	D 125	D250/ D500						D125	D250	D500	
15	95	400	450	165	222	60,3	45	4	184	15,88	10	12,2	15,9	
20	115	405	455	165	222	69,9	45	4	184	15,88	11,8	14	17,7	
25	125	410	460	165	222	79,4	45	4	184	15,88	13,3	15,5	19,2	
40	155	420	470	165	222	98,4	45	4	222	15,88	17,9	20,1	23,8	
50	165	430	480	165	222	120,7	45	4	254	19,05	20,8	23	26,7	
80	210	450	500	165	222	152,4	45	4	298	19,05	35,1	37,3	41	
100	248	460	510	165	222	190,5	22,5	8	352	19,05	47,9	50,1	53,8	
150	320	490	540	165	222	241,3	22,5	8	451	22,22	79,4	81,6	85,3	
200	380	546	570	165	222	298,5	15	12	543	25,4	131,39	133,59	138	

DN	ANSI 300									stroke
	P	M	numbers	L	R	weight (kg)				
						D125	D250	D500		
15	66,7	45	4	190	15,88	10,4	12,6	16,3	6	
20	82,6	45	4	194	19,05	13	15,2	18,9	6	
25	88,9	45	4	197	19,05	14,4	16,6	20,3	6	
40	114,3	45	4	235	22,22	20,7	22,9	26,6	6	
50	127	22,5	8	267	19,05	22,9	25,1	28,8	8	
80	168,3	22,5	8	318	22,22	39,2	41,4	45,1	8	
100	200	22,5	8	368	22,22	56,5	58,7	62,4	8,5	
150	269,9	15	12	473	22,22	98,4	100,6	104,3	8,5	
200	330,2	15	12	568	25,4	160	162	166	8,5	

Text and pictures are not binding. We reserve the right, to alter the equipment.