

DN 15 up to DN 50; PN 40

Pneumatically operated globe valve for the control of neutral, slightly aggressive and highly aggressive media.

- High Kvs Values
- Easy to isolate
- Compact design
- Unaffected by lightly contaminated media
- For temperatures from -100°C up to +220°C
- Working pressure up to 40 bar
- Actuator can be rotated
- Versatile customer-specific options

Technical Information

Nominal sizes	DN 15 up to DN 50
Body material	1.4408
Connection	Welding ends acc. ISO 1127
Nominal pressure	PN 40
Max. fluid temperature with metal bonnet	-30°C up to +170°C, opt. -100°C up to 220°C
with plastic bonnet	-30°C up to +135°C
with diaphragm actuator	-30°C up to +200°C, opt. -30°C up to 220°C
Ambient temperature	-15°C up to +60°C (special versions from -40°C up to +100°C)
Viscosity of media	maximum 600 mm ² /s (600cSt, 80°E)
Vakuum	maximum 0,001 bar abs
Working pressure	See tables and diagrams, limitation for dangerous gases acc. Pressure equipment directive 2014/68/EU (category I): PS x DN < 1000
Working pressure for packing underneath	maximum 12 bar
Leakage acc. EN 12266-1	leakage class A
Packing leakage	ISO FE BH-CC3-SSA1-t(-30°C, +80°C) Test pressure 40 bar



Options and accessories

- Stroke limitation
- Manual emergency operation
- El. position indicator with inductive or mechanical limit switches
- Solenoid valves
- AS-I control head
- Oil- and greasefree version, PTFE-free version, silicone free version
- Versions for oxygen or ozone applications
- FDA-compliant version
- Version acc. regulation (EG) 1935/2004
- Offshore-version
- Feedback unit for inductive limit switches
- Version for higher pilot pressures
- Version for under water use
- ...

Globe Valve 7017

Built up and function

Spring closes

The function „spring closes“ may be applied closing against or closing with the flow. In the configuration closing with the flow the valve should only be used for gaseous fluids. If used for liquids, water hammer may occur.

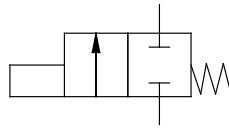

Removable position indicator

Bonnet can be rotated as required (compressed air connection)

Direct pressure control (with a pilot valve if required) actuation by air, water, mineral oil and other media

Head Section

Piston rod stainless steel

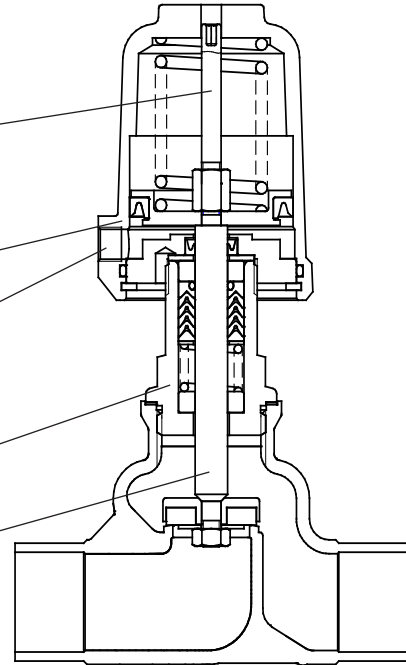

Spring opens

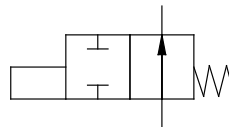

Bonnet material chrome plated brass, plastic, stainless steel or Aluminium

Exterior lip seal

Leak detector

PTFE packing, special version free or (packing underneath)

Seating seal in PTFE or other materials

Body

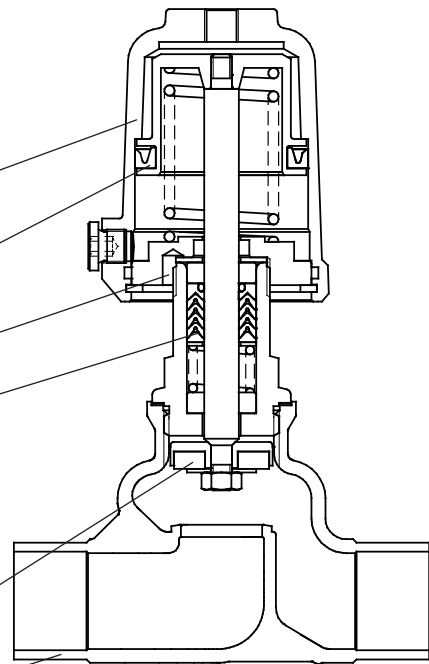

Pilot and operating pressures

Function „spring closes“, closing against flow

DN	Version	Actuator	Springs	Max. differential pressure [bar]			Pilot pressure [bar]
				PTFE	PEEK 7	PEEK 8	
Seating seal							
15	Standard	D50	1	21,5	-	17	3,5 - 10
			2	34,5	11,5	30	4,5 - 10
			3	40	26	40	5,7 - 10
		D80	1	40	40	40	3,5 - 10
			2	40	40	40	3,5 - 10
			3	40	40	40	3,5 - 10
20	Standard	D50	1	6,9	-	3,7	3,5 - 10
			2	12,5	-	9,6	4,5 - 10
			3	19	2,9	15,5	5,7 - 10
		D80	1	40	25	38	3,5 - 10
			2	40	38,5	40	4,4 - 10
			3	40	40	40	5,6 - 10
25	Standard	D50	1	2,4	-	-	3,5 - 10
			2	5,7	-	3,2	4,5 - 10
			3	9,1	-	6,6	5,7 - 10
		D80	1	22	9,9	19,5	3,5 - 10
			2	30	17,5	27,5	4,4 - 10
			3	39	27	36,5	5,6 - 10
		D125	1	19	6,7	16,5	1,3 - 10
			2	40	28	38	2,2 - 10
			3	40	40	40	3,1 - 10
32	Standard	D50	1	1	-	-	3,5 - 10
			2	3,1	-	1,1	4,5 - 10
			3	5,1	-	3,1	5,7 - 10
		D80	1	12,5	2,7	10,5	3,5 - 10
			2	17	7,3	15	4,4 - 10
			3	22	12,5	20,5	5,6 - 10
		D125	1	10,5	1,1	8,9	1,3 - 10
			2	23,5	14	21,5	2,2 - 10
			3	33,5	24	31,5	3,1 - 10
	D250	4	39	29,5	37	4,0 - 10	
		8	40	40	40	2,7 - 6	
		2	40	-	40	4,5 - 10	
pressure balanced	D50	1	40	40	40	3,5 - 10	
		2	40	40	40	4,4 - 10	
	D80	2	40	40	40	4,4 - 10	
40	Standard	D50	2	1,9	-	-	4,5 - 10
			3	3,3	-	1,6	5,7 - 10
			1	7,9	-	6,2	3,5 - 10
		D80	2	11	2,8	9,3	4,4 - 10
			3	14	6,2	12,5	5,6 - 10
			1	7	-	5,3	1,3 - 10
		D125	2	15,5	7,4	14	2,2 - 10
			3	22	14	20,5	3,1 - 10
			4	25	16,5	23,5	4,0 - 10
	d16	D250	8	32	24	30	2,7 - 6
			12	40	36,5	40	3,7 - 6
		D50	3	40	-	40	5,7 - 10
	pressure balanced	D50	1	40	-	40	3,5 - 10
			2	40	40	40	4,4 - 10
		D80	2	40	40	40	4,4 - 10

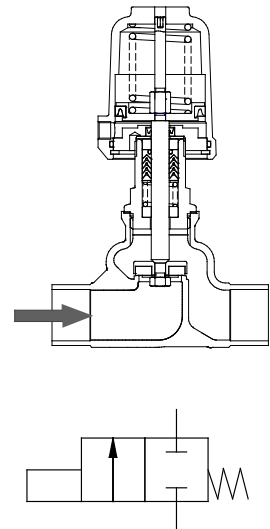

= Standard spring configuration

d16: reinforced design with 16mm piston rod

PEEK 7: Seating seal made of PEEK for use below 160°C

PEEK 8: Seating seal made of PEEK for use above 160°C

For soft seals such as EPDM, FKM, NBR or Vulkolan the same values as with PTFE are valid

Pilot and operating pressures

Function „spring closes“, closing against flow

DN	Version	Actuator	Springs	Max. differential pressure [bar]			Pilot pressure [bar]
				PTFE	PEEK 7	PEEK 8	
Seating seal				PTFE	PEEK 7	PEEK 8	
50	Standard	D50	2	1	-	-	4,5 - 10
			3	1,9	-	-	5,7 - 10
		D80	1	4,1	-	2,8	3,5 - 10
			2	5,9	-	4,6	4,4 - 10
			3	7,8	1,2	6,5	5,6 - 10
		D125	1	3,8	-	2,5	1,3 - 10
			2	9	2,4	7,6	2,3 - 10
			3	12,5	6	11	3,1 - 10
		d16	D125	4	13	6,8	12
	D250		8	19,5	13	18	2,7 - 6
			12	27,5	21	26	3,7 - 6
	pressure balanced	D50	2	31,5	-	-	4,5 - 10
			3	40	-	-	5,7 - 10
		D80	2	40	11	40	4,4 - 10
			3	40	40	40	5,6 - 10
		D125	2	40	40	40	2,2 - 10

= Standard spring configuration

d16: reinforced design with 16mm piston rod

PEEK 7: Seating seal made of PEEK for use below 160°C

PEEK 8: Seating seal made of PEEK for use above 160°C

For soft seals such as EPDM, FKM, NBR or Vulkolan the same values as with PTFE are valid

Pilot and operating pressures

Function „spring opens“, closing against flow

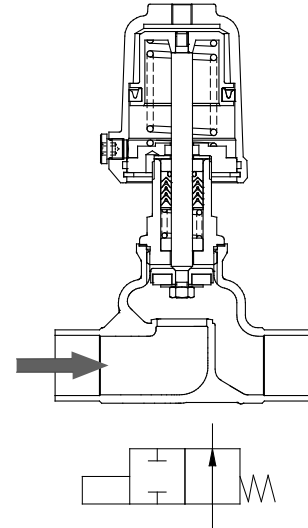

Seating seal PTFE, EPDM, FKM, NBR or Vulkolan

DN	Version	Actuator	Max. differential pressure [bar] at available pilot pressure [bar]																
			2	2,5	3	3,5	4	4,5	5	5,5	6	6,5	7	7,5	8	8,5	9	9,5	10
15	Standard	D50	0	0	6,6	13,5	20,5	27,5	34,5	40	40	-	-	-	-	-	-	-	-
		D80	40	40	-	-	-	-	-	-	-	-	-	-	-	-	-	-	-
20	Standard	D50	0	0	0,6	4,1	7,6	11	14,5	18	21	24,5	28	31,5	35	38,5	40	40	-
		D80	19,5	28,5	37,5	40	-	-	-	-	-	-	-	-	-	-	-	-	-
25	Standard	D50	0	0	0	1,2	3,3	5,3	7,4	9,5	11,5	13,5	15,5	17,5	19,5	21,5	23,5	26	28
		D80	10	15,5	21	26,5	32	37,5	40	40	-	-	-	-	-	-	-	-	-
32	Standard	D50	0	0	0	0,3	1,6	2,8	4,1	5,4	6,7	8	9,3	10,5	11,5	13	14	15,5	16,5
		D80	5,6	9	12	15,5	19	22,5	25,5	29	32,5	35,5	39	40	-	-	-	-	-
		D125	24,5	32,5	40	-	-	-	-	-	-	-	-	-	-	-	-	-	-
40	Standard	D50	0	0	0	0	0,8	1,7	2,6	3,5	4,4	5,3	6,2	7,1	8	8,9	9,8	10,5	11,5
		D80	3,4	5,8	8,1	10,5	12,5	15	17,5	19,5	22	24,5	26,5	29	31,5	34	36	38,5	40
		D125	16,5	22	28	34	29,5	40	-	-	-	-	-	-	-	-	-	-	-
50	Standard	D50	0	0	0	0	0,3	0,8	1,4	2	2,6	3,2	3,7	4,3	4,9	5,5	6	6,6	7,2
		D80	1,7	3,2	4,7	6,2	7,7	9,2	10,5	12	13,5	15	16,5	18	19,5	21	22,5	24	25,5
		D125	10	13,5	17,5	21	25	28,5	32,5	36	40	-	-	-	-	-	-	-	-

d16: reinforced design with 16mm piston rod

Actuator D50: max. pilot pressure 1 bar above the required pilot pressure

Actuator D80: max. pilot pressure 0,8 bar above the required pilot pressure

Actuator D125 and D250: max. pilot pressure 0,5 bar above the required pilot pressure

Pilot and operating pressures

Function „spring opens“, closing against flow

Seating seal PEEK-8

DN	Version	Actuator	Max. differential pressure [bar] at available pilot pressure [bar]																
			2	2,5	3	3,5	4	4,5	5	5,5	6	6,5	7	7,5	8	8,5	9	9,5	10
15	Standard	D50	0	0	2	9	16	23	30	37	40	40	-	-	-	-	-	-	-
		D80	39,5	40	-	-	-	-	-	-	-	-	-	-	-	-	-	-	-
20	Standard	D50	0	0	0	0,9	4,3	7,8	11	14,5	18	21,5	25	28,5	32	35,5	39	40	40
		D80	16	25	34	40	40	-	-	-	-	-	-	-	-	-	-	-	-
25	Standard	D50	0	0	0	0	0,8	2,9	4,9	7	9	11	13	15	17	19	21	23,5	25,5
		D80	7,9	13	18,5	24	29,5	35	40	40	-	-	-	-	-	-	-	-	-
32	Standard	D50	0	0	0	0	0	0,9	2,2	3,4	4,7	6	7,3	8,6	9,9	11	12	13,5	15
		D80	3,7	7	10	13,5	17	20,5	23,5	27	30,5	34	37	40	40	-	-	-	-
		D125	22,5	30,5	39	40	-	-	-	-	-	-	-	-	-	-	-	-	-
40	Standard	D80	1,8	4,1	6,5	8,8	11	13,5	15,5	18	20,5	23	25	27,5	30	32	34,5	37	39
		D125	15	20,5	26,5	32	38	40	-	-	-	-	-	-	-	-	-	-	-
50	Standard	D80	0,3	1,9	3,4	4,9	6,4	7,9	9,4	11	12,5	14	15,5	17	18,5	20	21,5	23	24,5
		D125	8,8	12,5	16	20	23,5	27,5	31	35	38,5	40	-	-	-	-	-	-	-

Seating seal PEEK-7

DN	Version	Actuator	Max. differential pressure [bar] at available pilot pressure [bar]																
			2	2,5	3	3,5	4	4,5	5	5,5	6	6,5	7	7,5	8	8,5	9	9,5	10
15	Standard	D50	0	0	0	0	0	4,7	11,5	18,5	25,5	32,5	39,5	40	40	-	-	-	-
		D80	21,5	39,5	40	-	-	-	-	-	-	-	-	-	-	-	-	-	-
20	Standard	D50	0	0	0	0	0	0	1,8	5,3	8,8	12	15,5	19	22,5	26	29,5	33	
		D80	3,3	12	21,5	30,5	39,5	40	-	-	-	-	-	-	-	-	-	-	-
25	Standard	D80	0	3,3	8,8	14	19,5	25	30,5	35,5	40	40	-	-	-	-	-	-	-
		D125	28	40	-	-	-	-	-	-	-	-	-	-	-	-	-	-	-
32	Standard	D80	0	0	2,6	5,9	9,3	12,5	16	19	22,5	26	29,5	32,5	36	39,5	40	-	-
		D125	14,5	23	31	39,5	40	-	-	-	-	-	-	-	-	-	-	-	-
40	Standard	D80	0	0	0	2,3	4,6	7	9,3	11,5	14	16	18,5	21	23,5	25,5	28	30,5	32,5
		D125	8,4	14	20	25,5	31,5	37	40	-	-	-	-	-	-	-	-	-	-
50	Standard	D80	0	0	0	0	1,1	2,7	4,2	5,7	7,2	8,7	10	11,5	13	14,5	16	17,5	19
		D125	3,6	7,3	11	14,5	18,5	22	26	29,5	33	37	40	-	-	-	-	-	-
		D250	4,5	12	19,5	27	35	40	-	-	-	-	-	-	-	-	-	-	-

d16: reinforced design with 16mm piston rod

PEEK 7: Seating seal made of PEEK for use below 160°C

PEEK 8: Seating seal made of PEEK for use above 160°C

Actuator D50: max. pilot pressure 1 bar above the required pilot pressure

Actuator D80: max. pilot pressure 0,8 bar above the required pilot pressure

Actuator D125 and D250: max. pilot pressure 0,5 bar above the required pilot pressure

Pilot and operating pressures

Function „spring closes“, closing with flow

- Angled seat valve closing with the flow, spring closes
- Use preferably for gaseous fluids
- With liquids waterhammers are possible

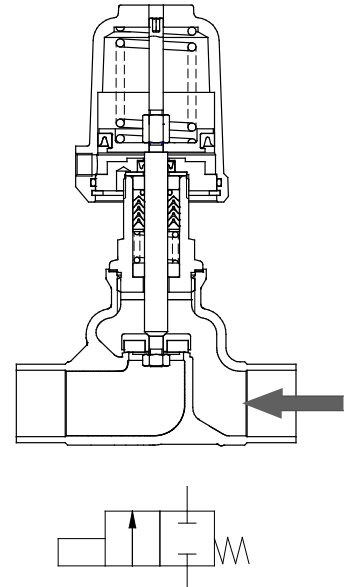

Seating seal PTFE, EPDM, FKM, NBR or Vulkolan

DN	Version	Actuator	Springs	Max. differential pressure [bar] at available pilot pressure [bar]																
				2	2,5	3	3,5	4	4,5	5	5,5	6	6,5	7	7,5	8	8,5	9	9,5	10
15	Standard	D50	Standard	0	0	21,5	38,5	40	40	40	40	40	40	40	40	40	40	40	40	40
		D80	Standard	25,5	38,5	40	40	40	40	40	40	40	40	40	40	40	40	40	40	40
20	Standard	D50	Standard	0	0	8,7	13,5	18	23	28	33	37,5	40	40	40	40	40	40	40	40
		D80	Standard	25,5	38,5	40	40	40	40	40	40	40	40	40	40	40	40	40	40	40
25	Standard	D50	Standard	0	0	5,2	7,7	10	12,5	15	17,5	20	22,5	25	27,5	30	32,5	33	33	33
		D80	Standard	13,5	20	26,5	33	33	33	33	33	33	33	33	33	33	33	33	33	33
32	Standard	D50	Standard	0	0	3	4,4	5,9	7,3	8,7	10	11,5	13	14,5	15,5	17	18,5	19	19	19
		D80	Standard	8	11,5	15,5	19	23	26,5	30,5	34	35	35	35	35	35	35	35	35	35
		D125	Standard	28,5	35	35	35	35	35	35	35	35	35	35	35	35	35	35	35	35
40	Standard	D50	Standard	0	0	0	2,4	3,4	4,3	5,3	6,3	7,2	8,2	9,2	10	11	12	13	13	13
		D80	Standard	0	5,1	7,7	10	12,5	15	17,5	20	22,5	23	23	23	23	23	23	23	23
		D125	Standard	12,5	18,5	23	23	23	23	23	23	23	23	23	23	23	23	23	23	23
		d16	D125	1	12	18,5	24,5	30,5	37	40	40	40	40	40	40	40	40	40	40	
50	Standard	D50	Standard	0	0	0	1,4	2	2,6	3,2	3,9	4,5	5,1	5,7	6,3	6,9	7,5	8	8	8
		D80	Standard	0	3,6	5,2	6,8	8,4	10	11,5	13	14,5	15	15	15	15	15	15	15	15
		D125	Standard	8,3	12	15	15	15	15	15	15	15	15	15	15	15	15	15	15	15
		d16	D125	1	8,1	12	15,5	19,5	23,5	27,5	31	35	38	38	38	38	38	38	38	

d16: reinforced design with 16mm piston rod

Pilot and operating pressures

Function „spring closes“, closing with flow

Seating seal PEEK-8

DN	Ver- sion	Actu- ator	Springs	Max. differential pressure [bar] at available pilot pressure [bar]																
				2	2,5	3	3,5	4	4,5	5	5,5	6	6,5	7	7,5	8	8,5	9	9,5	10
15	Stan- dard	D50	2	0	0	0	0	4	20,5	37,5	40	40	40	40	40	40	40	40	40	40
20	Stan- dard	D50	2	0	0	1,1	6	10,5	15,5	20,5	25,5	30	35	40	40	40	40	40	40	40
		D80	1	0	0	1,8	14,5	27	40	40	40	40	40	40	40	40	40	40	40	40
		125	1	30	33	33	33	33	33	33	33	33	33	33	33	33	33	33	33	33
25	Stan- dard	D50	2	0	0	2,1	4,6	7,1	9,6	12	14,5	17	19,5	22	24,5	27	29,5	32	33	33
		D80	1	0	0	2,8	9,4	15,5	22,5	29	33	33	33	33	33	33	33	33	33	33
		D125	1	30	33	33	33	33	33	33	33	33	33	33	33	33	33	33	33	33
32	Stan- dard	D50	2	0	0	1,3	2,7	4,1	5,6	7	8,5	9,9	11	12,5	14	15,5	17	18,5	19	19
		D80	1	0	0	2,6	6,4	10	13,5	17,5	21,5	25	29	32,5	35	35	35	35	35	35
		D125	1	18	27	35	35	35	35	35	35	35	35	35	35	35	35	35	35	35
40	Stan- dard	D80	1	0	0	2,4	5	7,5	10	12,5	15	17,5	20	22,5	23	23	23	23	23	23
		D125	2	3,2	9,5	15,5	22	23	23	23	23	23	23	23	23	23	23	23	23	23
	d16	D125	2	3	9,2	15	21,5	27,5	34	40	40	40	40	40	40	40	40	40	40	
50	Stan- dard	D80	2	0	0	0,3	1,9	3,5	5,1	6,7	8,2	9,8	11	13	14,5	15	15	15	15	15
		D125	2	2,9	6,8	10,5	14,5	15	15	15	15	15	15	15	15	15	15	15	15	15
	d16	D125	2	2,7	6,6	10,5	14	18	22	26	29,5	33,5	37,5	38	38	38	38	38	38	38
		D250	6	12,5	20,5	28,5	36,5	38	38	38	38	38	-	-	-	-	-	-	-	

Seating seal PEEK-7

DN	Ver- sion	Actu- ator	Springs	Max. differential pressure [bar] at available pilot pressure [bar]																
				2	2,5	3	3,5	4	4,5	5	5,5	6	6,5	7	7,5	8	8,5	9	9,5	10
15	Stan- dard	D50	2	0	0	0	0	4	20,5	37,5	40	40	40	40	40	40	40	40	40	40
20	Stan- dard	D80	1	0	0	1,8	14,5	27	40	40	40	40	40	40	40	40	40	40	40	40
		125	1	40	40	40	40	40	40	40	40	40	40	40	40	40	40	40	40	
25	Stan- dard	D80	1	0	0	2,8	9,4	15,5	22,5	29	33	33	33	33	33	33	33	33	33	33
		125	1	30	33	33	33	33	33	33	33	33	33	33	33	33	33	33	33	
32	Stan- dard	D80	2	0	0	1,2	5	8,8	12,5	16	20	23,5	27,5	31	35	35	35	35	35	35
		D125	1	18	27	35	35	35	35	35	35	35	35	35	35	35	35	35	35	
40	Stan- dard	D80	2	0	0	0,8	3,3	5,8	8,3	10,5	13	15,5	18	20,5	23	25,5	28	30,5	33	33
		D125	2	3,2	9,5	15,5	22	23	23	23	23	23	23	23	23	23	23	23	23	
	d16	D125	2	3	9,2	15	21,5	27,5	34	40	40	40	40	40	40	40	40	40		
50	Stan- dard	D125	2	2,9	6,8	10,5	14,5	15	15	15	15	15	15	15	15	15	15	15	15	15
		D125	2	2,7	6,6	10,5	14	18	22	26	29,5	33,5	37,5	38	38	38	38	38	38	
	d16	D250	6	12,5	20,5	28,5	36,5	38	38	38	38	38	-	-	-	-	-	-		

d16: reinforced design with 16mm piston rod
 PEEK 7: Seating seal made of PEEK for use below 160°C
 PEEK 8: Seating seal made of PEEK for use above 160°C

Ordering Number System

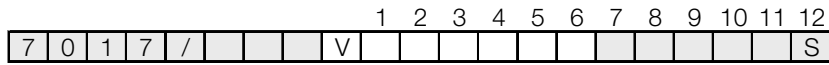

1 - 6 : Please quote all 6 sections.
7 - 12: Quote only if required.

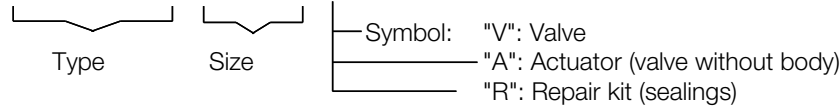

1.	Body type	2.	Connection	3.	Body materials	4.	Seat materials	5.	Pilot function	6.	Actuator, Ø
0	Globe valve	H	Welding ends acc. ISO 1127	2	Stainless steel (rustproof, acid resistant) PN 40 1.4408	0 1 2 3 5 6 7 8	PTFE FKM EPDM NBR PTFE with 25% glass fibre Vulkollan PEEK PEEK for applications above 320°F	0 1 2	NC (closing with flow) NO (closing against flow) NC (closing against flow)	0 1 2 C K M	Piston 50 mm Piston 80 mm Piston 125 mm diaphragm D250 mm piston Ø50mm with plastic bonnet piston Ø80mm with plastic bonnet
7.	Springs	8.	Head section material	9.	Packing	10.	Temperature version	11.	Accessories	12.	Other special versions
- 1 2 3 T W Y	Standard 1 spring 2 springs 3 springs 6 springs (D250) 8 springs (D250) 12 springs (D250)	- K	Standard head section (stainless steel) and piston rod reinforced (16 mm piston rod)	- 2	Standard Packing underneath	- H V	Standard High temperature version +200°C Viton exterior lip seal	- 1 2 3 4 5 6 7 K M P T	No accessories Electrical position indicator with one switch As above but with two switches Manual emergency operation Additional manual operation Stroke limitation Pilot valve DN 2, 230 V AC Pilot valve DN 2, 24 V DC Electr. position indicator compact Position indicator with two ind. Switch 10 - 36 V DC (PNP) Position indicator with one ind. Switch 10 - 36 V DC (PNP) Position indicator compact, inductive 10 - 30 V DC (PNP)	M N S	Position indicator with cable bushing Position indicator with plug connection If after inquiries, further special versions are agreed upon insert „S“ here!

Ordering example: 7017/025V0H2021----7

Right angled globe valve type 7017, size DN 25, with welding ends acc. ISO 1127, body material stainless steel, seating seal PTFE, pilot function NC (closing against flow), piston actuator 80 mm, standard spring configuration (2 springs), pilot valve DN 2, 24 V DC

Standard design

Dimensions and weights

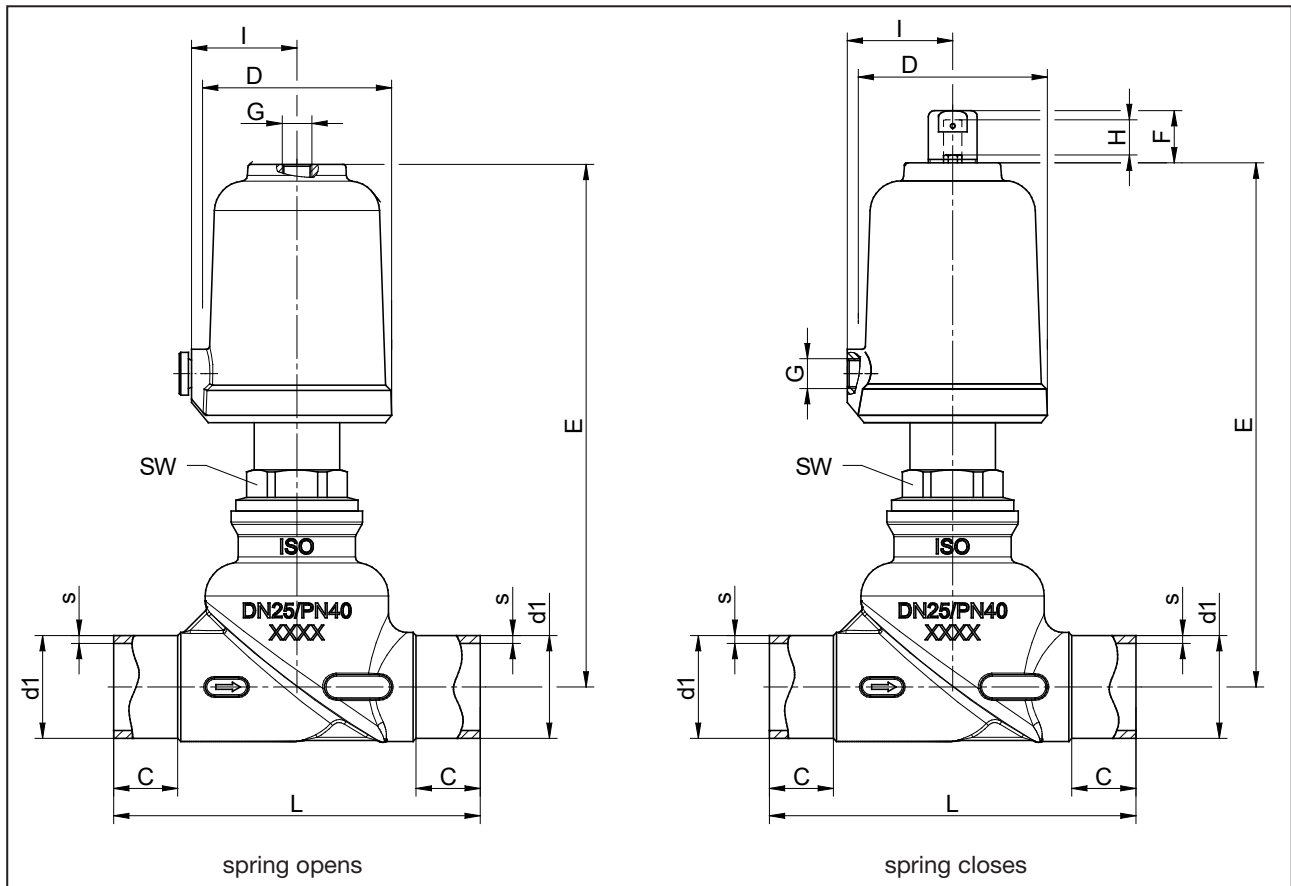

DN	Actuator	Welding ends acc ISO 1127 - B				D	E	F	G	H (stroke)	I	SW		Kvs-values	Weight (kg)
		d1	s	C	L							standard	reinforced		
15	D50	21,3	2	20	95	62	154	16	G1/8"	7	34,5	30	-	4,2	1,1
20	D50	26,9	2,3	22	110	62	163	16	G1/8"	12	34,5	30	-	9	1,2
25	D50	33,7	2,6	21	120	62	173	16	G1/8"	16	34,5	30	-	15	1,4
	D80	33,7	2,6	21	120	96	210	37	G1/4"	16	55	30	-	16	3
32	D50	42,4	2,6	20	140	62	192	16	G1/8"	16	34,5	30	-	23	1,8
	D80	42,4	2,6	20	140	96	231	37	G1/4"	20	55	30	-	24	3,3
	D125	42,4	2,6	20	140	146	256	37	G1/4"	20	80	30	-	24	5,5
40	D50	48,3	2,6	22	160	62	197	16	G1/8"	16	34,5	30	-	33	2,1
	D80	48,3	2,6	22	160	96	236	37	G1/4"	23	55	30	-	35	3,6
	D125	48,3	2,6	22	160	146	261	37	G1/4"	23	80	30	-	35	5,8
50	D50	60,3	2,9	28	190	62	209	16	G1/8"	16	34,5	32	-	46	2,7
	D80	60,3	2,9	28	190	96	248	37	G1/4"	29	55	32	36	47	4,2
	D125	60,3	2,9	28	190	146	273	37	G1/4"	29	80	32	36	47	6,4

Dimensions in mm

Reinforced design

Dimensions and weights

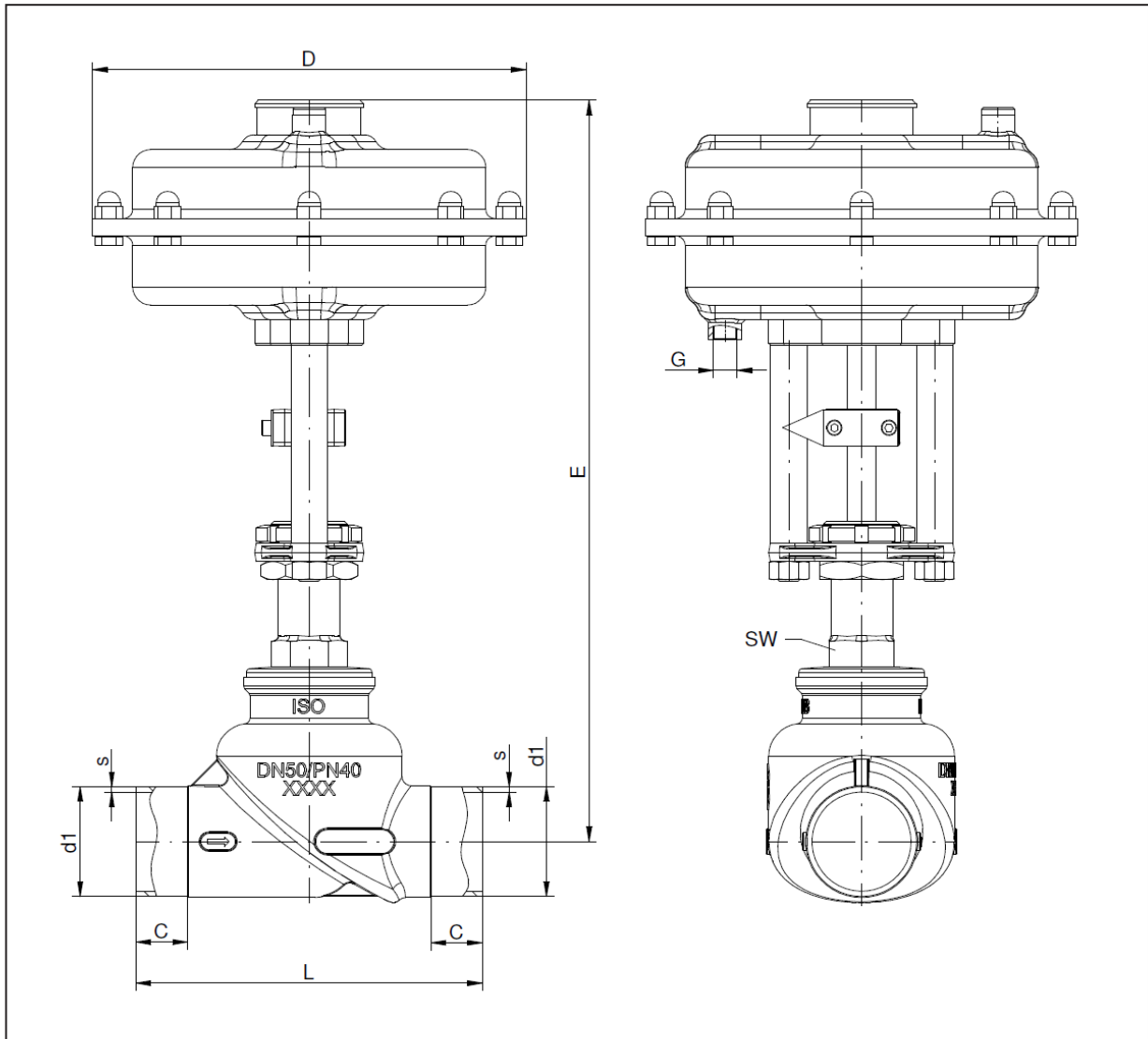

DN	Actuator	Welding ends acc ISO 1127 - B				D	E	G	H (stroke)	SW reinforced	Kvs- values	Weight (kg)
		d1	s	C	L							
50	D250	60,3	2,9	28	190	238	408	G1/4"	25	36	47	6,5

Dimensions in mm

Globe Valve 7017

Pressure balanced version



Built up, dimensions and weights

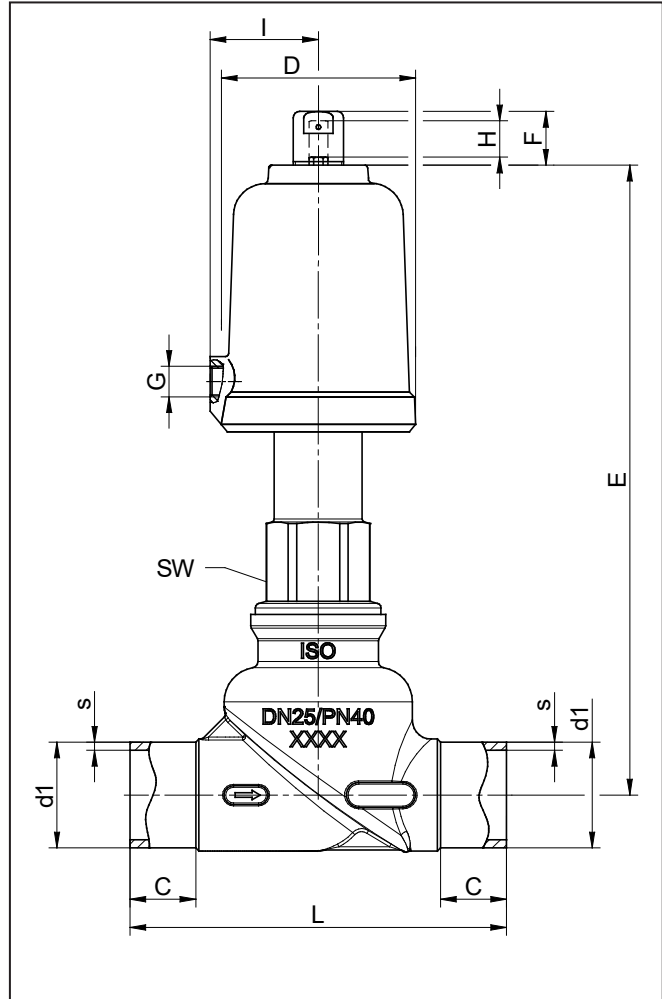
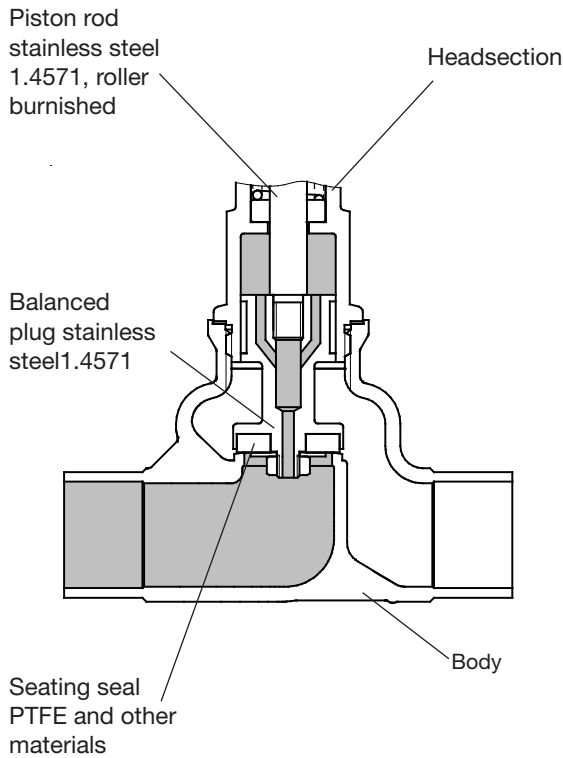

DN	Actuator	Welding ends acc ISO 1127 - B				D	E	F	G	H (stroke)	I	SW	Kvs- values	Weight (kg)
		d1	s	C	L									
32	D50	42,4	2,6	20	140	62	214	16	G1/8"	16	34,5	30	23	2,0
	D80	42,4	2,6	20	140	96	253	37	G1/4"	20	55	30	24	3,5
	D125	42,4	2,6	20	140	146	278	37	G1/4"	20	80	30	24	5,7
40	D50	48,3	2,6	22	160	62	224	16	G1/8"	16	34,5	30	33	2,3
	D80	48,3	2,6	22	160	96	263	37	G1/4"	23	55	30	35	3,8
	D125	48,3	2,6	22	160	146	288	37	G1/4"	23	80	30	35	6,0
50	D50	60,3	2,9	28	190	62	243	16	G1/8"	16	34,5	32	46	3,2
	D80	60,3	2,9	28	190	96	282	37	G1/4"	29	55	32	47	4,7
	D125	60,3	2,9	28	190	146	307	37	G1/4"	29	80	32	47	6,9

Dimensions in mm

Dimensions and weights

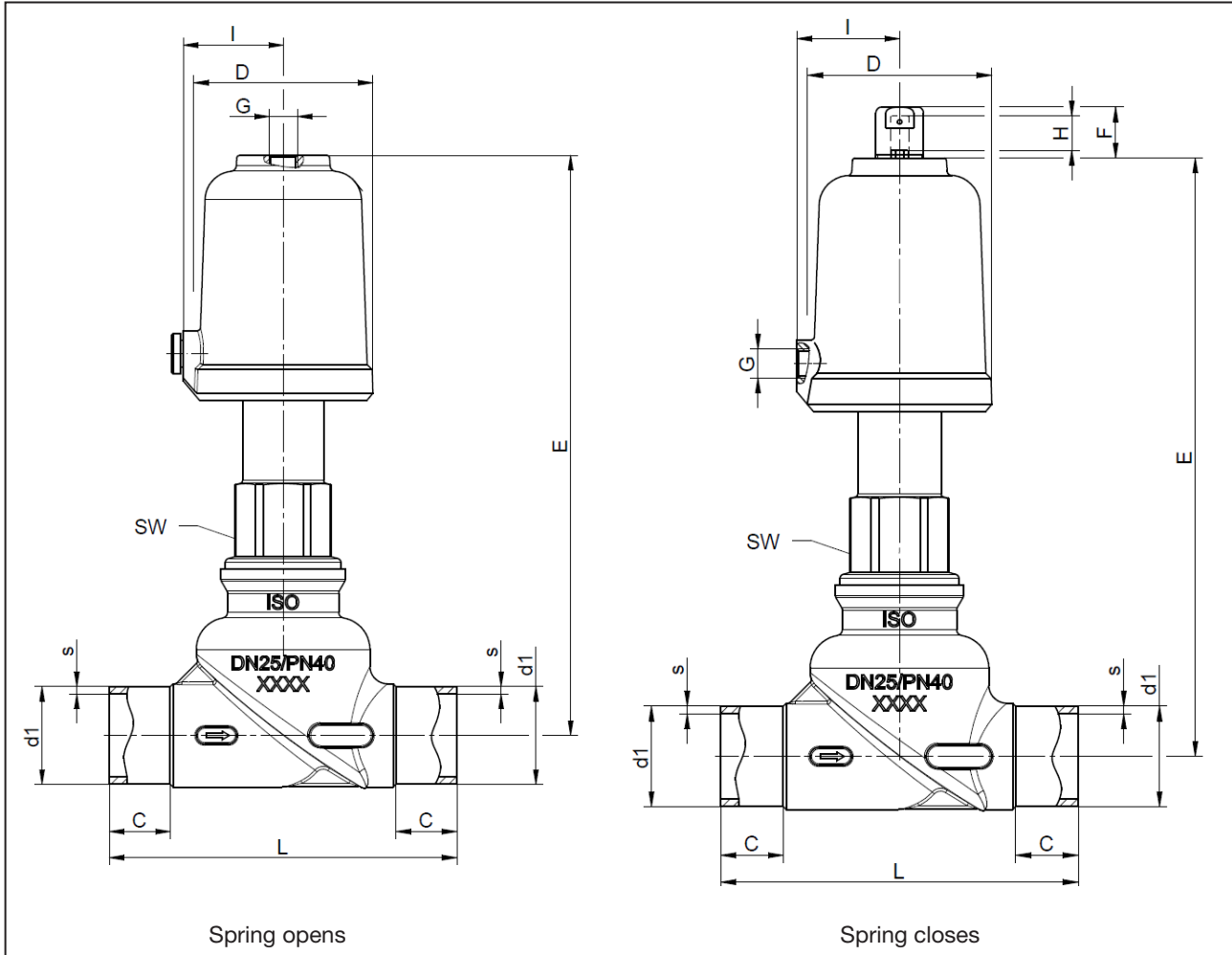

DN	Actuator	Welding ends acc ISO 1127 - B				D	E	F	G	H (stroke)	I	SW		Kvs-values	Weight (kg)
		d1	s	C	L							standard	reinforced		
15	D50	21,3	2	20	95	62	176	16	G1/8"	7	34,5	30	-	4,2	1,2
20	D50	26,9	2,3	22	110	62	185	16	G1/8"	12	34,5	30	-	9	1,3
25	D50	33,7	2,6	21	120	62	195	16	G1/8"	16	34,5	30	-	15	1,5
	D80	33,7	2,6	21	120	96	232	37	G1/4"	16	55	30	-	16	3,1
32	D50	42,4	2,6	20	140	62	214	16	G1/8"	16	34,5	30	-	23	1,9
	D80	42,4	2,6	20	140	96	253	37	G1/4"	20	55	30	-	24	3,4
	D125	42,4	2,6	20	140	146	278	37	G1/4"	20	80	30	-	24	5,6
40	D50	48,3	2,6	22	160	62	219	16	G1/8"	16	34,5	30	-	33	2,2
	D80	48,3	2,6	22	160	96	258	37	G1/4"	23	55	30	-	35	3,7
	D125	48,3	2,6	22	160	146	283	37	G1/4"	23	80	30	-	35	5,9
50	D50	60,3	2,9	28	190	62	231	16	G1/8"	16	34,5	32	-	46	2,8
	D80	60,3	2,9	28	190	96	270	37	G1/4"	29	55	32	36	47	4,3
	D125	60,3	2,9	28	190	146	295	37	G1/4"	29	80	32	36	47	6,5

Dimensions in mm