

USER GUIDE: 17 118 6204 07/21 Rev A

Maintenance Guide: 17 118 6201

Installation & Setup Guide: 17 118 6202

OIL-X COMPRESSED AIR FILTER

Filters for Compressed Air

PX010 - PX055 (WS, A0, AA, ACS)

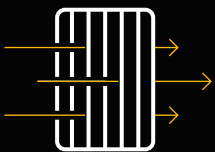

**Filtration
User Guide**

(EN)



CONTENTS

04	- Installing the OIL-X System	14	- Video: How-To Guide
05	- Installation Recommendations	16	- Model Coding - Water Separator Flow Rates
07	- Start-Up Procedure - Running Configuration	17	- Filter Flow Rates - Technical Data
09	- Maintenance Intervals	18	- Water Separator Weights and Dimensions
10	- System Depressurisation - Filter Bowl Removal	19	- Filter Weights and Dimensions
11	- Removal of Element from Filter Bowl - Automatic Drain Replacement	20	- Filter Flow Rates
12	- Insertion of Replacement Element into Filter Bowl - Replacement of Filter Head O Ring Seal - Reconnecting the Filter Bowl with Head	21	- Accessories / Spare Parts
13	- Service Reminder Label - System Start-up Procedure	22	- Declaration of Conformity
		23	- Parker Worldwide

INSTALLATION RECOMMENDATIONS

INSTALLING THE OIL-X SYSTEM

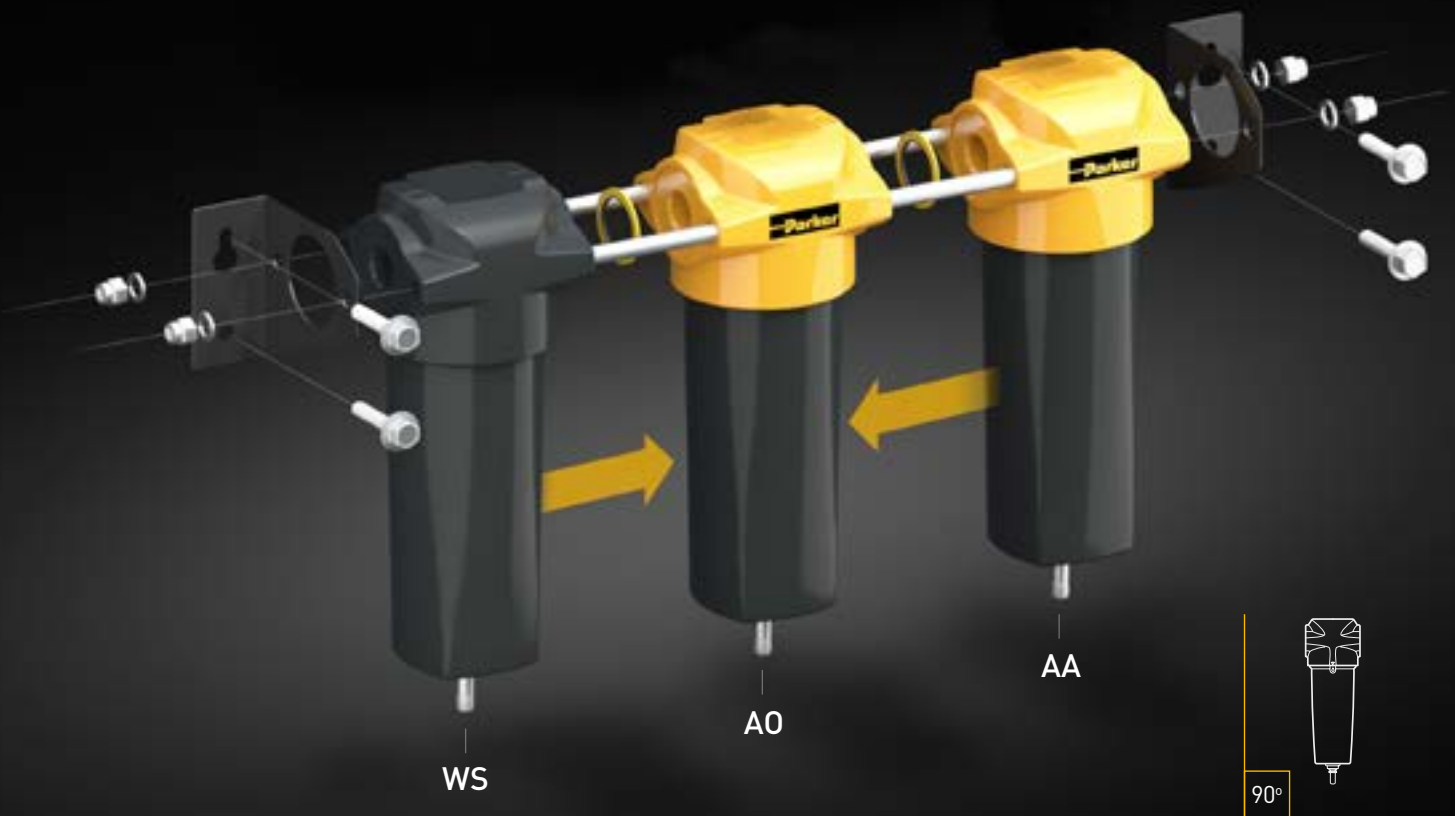

Before pressurising the filter ensure that the head and bowl are correctly fitted and that the locking detail is properly aligned as shown in the maintenance section of this manual.

MODELS 050 AND 055 ONLY

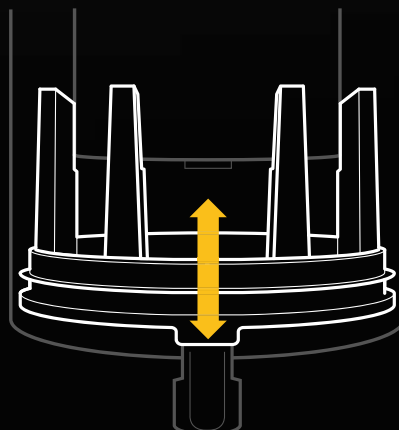

The lower closure plate may move when the filter is not pressurised

The lower closure plate is a non serviceable item and should never be removed.

INSTALLATION RECOMMENDATIONS

- It is recommended that the compressed air is treated prior to entry into the distribution system and also at critical usage points / applications.
- Installation of compressed air dryers to a previously wet system could result in additional dirt loading for point of use filters for a period whilst the distribution system dries out.
- Filter elements may need to be changed more frequently during this period.
- For installations where oil-free compressors are used, water aerosol and particulate are still present, general purpose and high efficiency grades should still be used.
- A general purpose filter must always be installed to protect the high efficiency filter from bulk liquid aerosols and solid particulate.
- Install purification equipment at the lowest temperature above freezing point, preferably downstream of after coolers and air receivers.
- Point of use purification equipment should be installed as close to the application as possible.
- Purification equipment should not be installed downstream of quick opening valves and should be protected from possible reverse flow or other shock conditions.
- Purge all piping leading to the purification equipment before installation and all piping after the purification equipment is installed and before connection to the final application.
- If by-pass lines are fitted around purification equipment, ensure adequate filtration is fitted to the by-pass line to prevent contamination of the system downstream.
- Fit drain lines from the coalescing filters directly to a condensate separator. If it is not possible to connect the drain lines directly to a separator, the lines should be vented in to a condensate manifold (vented at one end) and then in to a single inlet of a condensate separator.
- Provide a facility to drain away collected liquids from the purification equipment.
- Collected liquids should be treated and disposed of in a responsible manner.

START-UP PROCEDURE

START-UP PROCEDURE

Before pressurising the filter ensure that the head and bowl are correctly fitted and that the locking detail is properly aligned. Slowly open the inlet valve (01) to gradually pressurise the filter and wait 1 minute (02) before slowly opening the outlet valve (03) to re-pressurise the downstream piping.

Note: Do not open inlet or outlet valves rapidly or subject unit to excessive pressure differential as damage may occur.

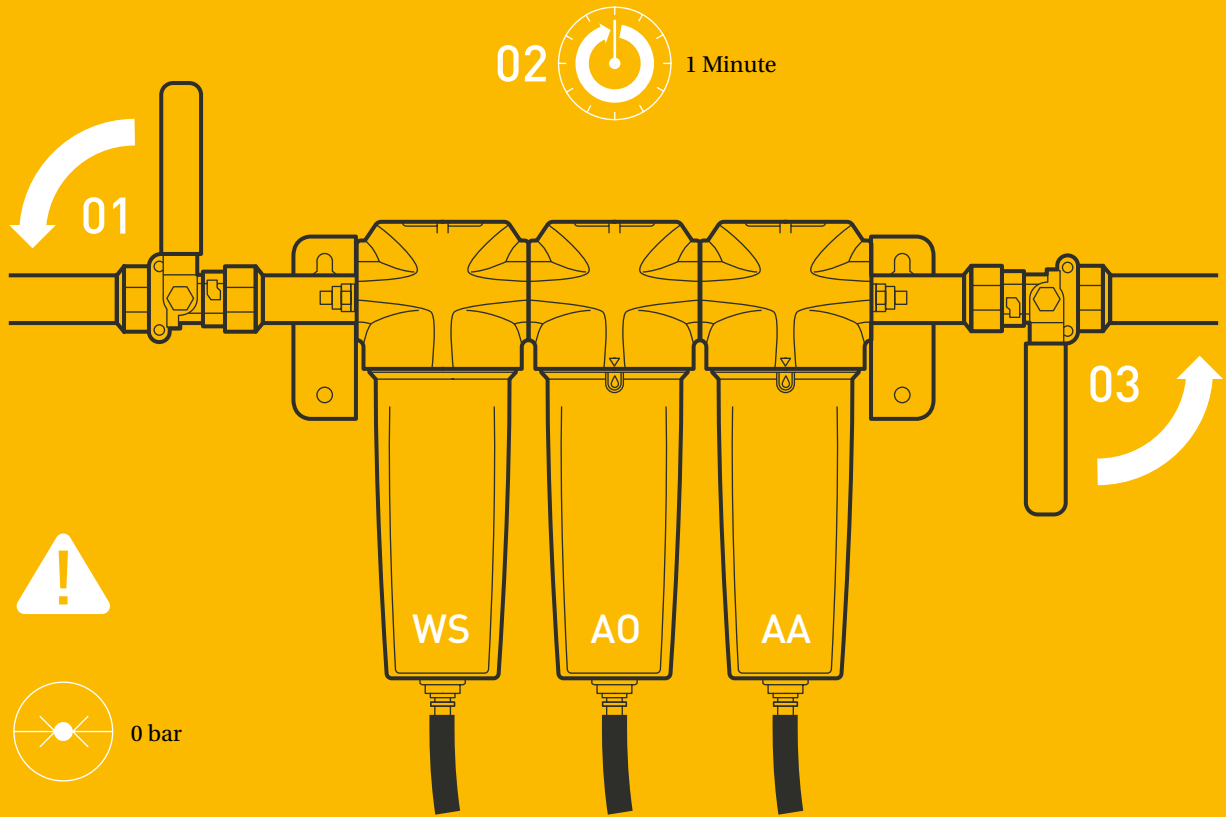

RUNNING CONFIGURATION

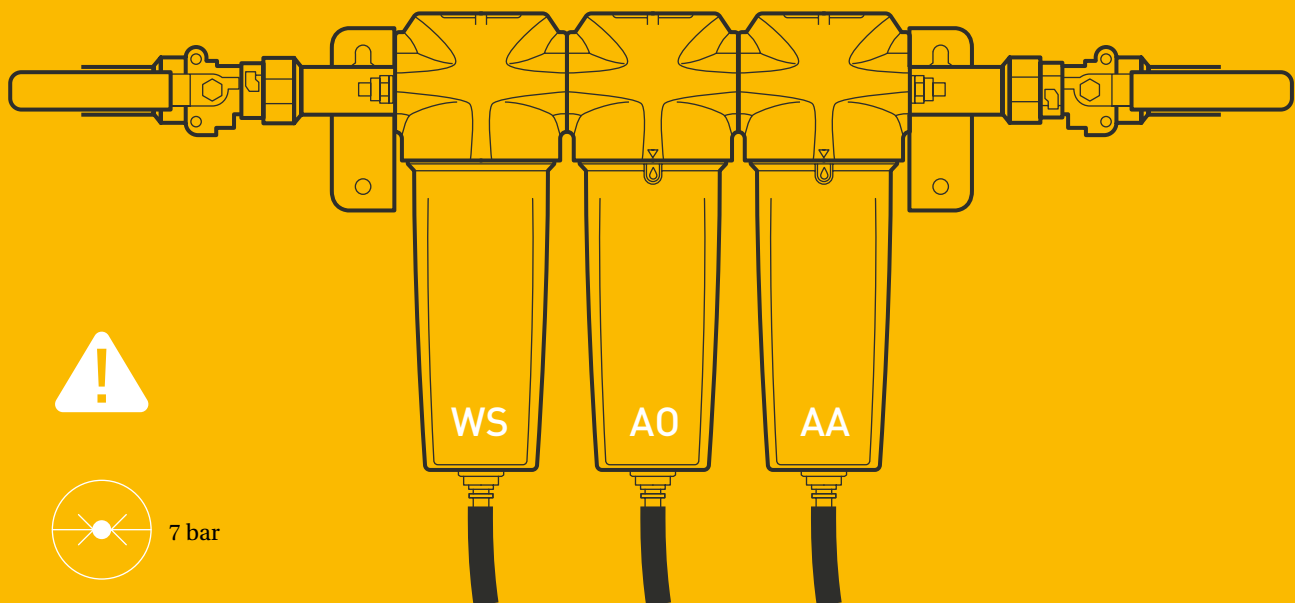

PRODUCT MAINTENANCE

MAINTENANCE INTERVALS

To ensure optimal filter performance the OIL-X Grade AO and OIL-X Grade AA coalescing and dry particulate filter elements require changing every 12 months (8736 hours) along with the automatic float drain.

Unlike coalescing and dry particulate filter elements which are changed annually to guarantee compressed air quality, the lifetime of an adsorption filter element / cartridge can be attributed to various factors and will require more frequent changes. Factors affecting the lifetime of adsorption filters are:

Oil vapour concentration

The higher the inlet concentration of oil vapour, the faster the adsorption material capacity will be used, resulting in reduced adsorption filter element / cartridge lifetime.

Bulk oil

Adsorption filters are designed only to reduce oil vapours and odours, not liquid oil or oil aerosols. Poorly maintained or non-existent pre-filtration (coalescing filters) will cause the adsorption filter capacity to be used quickly resulting in reduced adsorption filter element / cartridge lifetime.

Temperature

Oil vapour content increases exponentially to inlet temperature, reducing adsorption filter element / cartridge lifetime. Additionally, as temperature increases, the adsorption capacity of the adsorbent material decreases, again reducing adsorption filter element / cartridge lifetime.

Relative Humidity or Dewpoint

Wet air reduces the adsorptive capacity of the adsorbent material, reducing adsorption filter element / cartridge lifetime. Ideally, in-line adsorption filters should always be placed downstream of a compressed air dryer to prolong adsorption filter element / cartridge lifetime.

Compressor oil changes

When compressor oil is changed, the new lubricant burns off "light ends" which increases the oil vapour content for hours or even weeks afterwards. This increase in oil vapour content is adsorbed by the adsorption filter element / cartridge, reducing the adsorption filter element / cartridge lifetime.

OIL-X Grade ACS Adsorption Filters

The performance of the OIL-X Grade ACS element is based upon a nominal inlet temperature of 21°C, with a pressure dewpoint of -40°C and a maximum oil vapour inlet concentration of 0.018mg/m³. Under these conditions, OIL-X Grade ACS will have a lifetime of 650 hours. Operating OIL-X grade ACS at higher inlet temperatures / higher inlet oil vapour concentrations / or before a refrigeration or adsorption dryer will result in lower adsorption filter lifetime. Replace the carbon filter element upon detection of vapour, odour or taste. OIL-X Grade ACS are recommended for point of use applications only where frequent element changes are acceptable.

OIL-X Grade OVR Adsorption Filters

Unlike in-line adsorption filters (OIL-X Grade ACS), OIL-X Grade OVR adsorption filters are sized and selected to not only provide consistent air quality but to also provide 12 months of cartridge life. This 12 month (6000 hours for models OVR 100 ~ OVR 250 and 8736 hours for models OVR 300 ~ OVR 550) cartridge life is dependent upon sizing for the following inlet parameters: maximum inlet temperature / compressor type, minimum inlet pressure, position in system (before or after a dryer) and inlet oil vapour content. OIL-X Grade OVR adsorption filters are designed for both plant scale (compressor room) and point of use applications.

SYSTEM DEPRESSURISATION

Slowly close the inlet (01) and outlet (02) valves and depressurise the filter (03) using the drain.

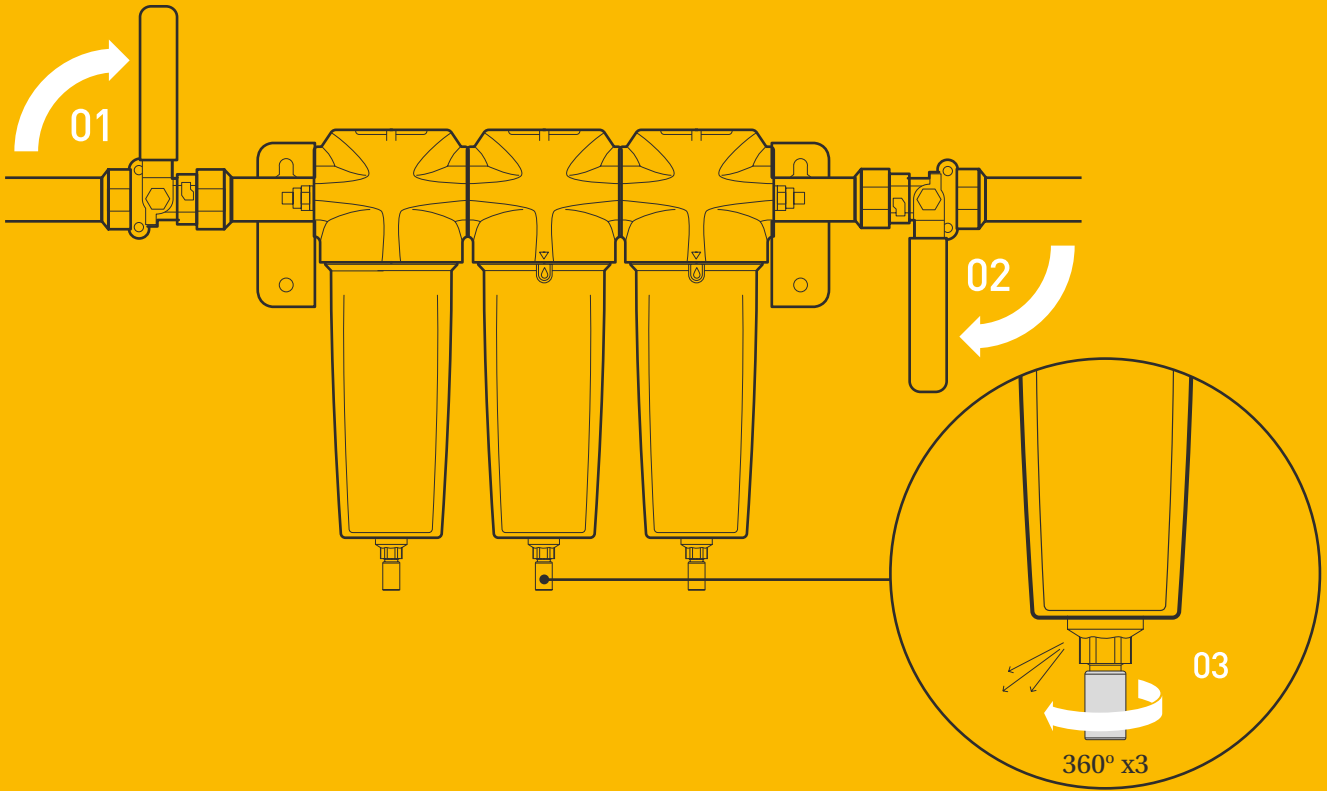

FILTER BOWL REMOVAL

Unscrew the filter bowl (01 & 02) and remove the used element (03).

Note: A strap wrench may be required for the removal of the 050 & 055 filter bowl.

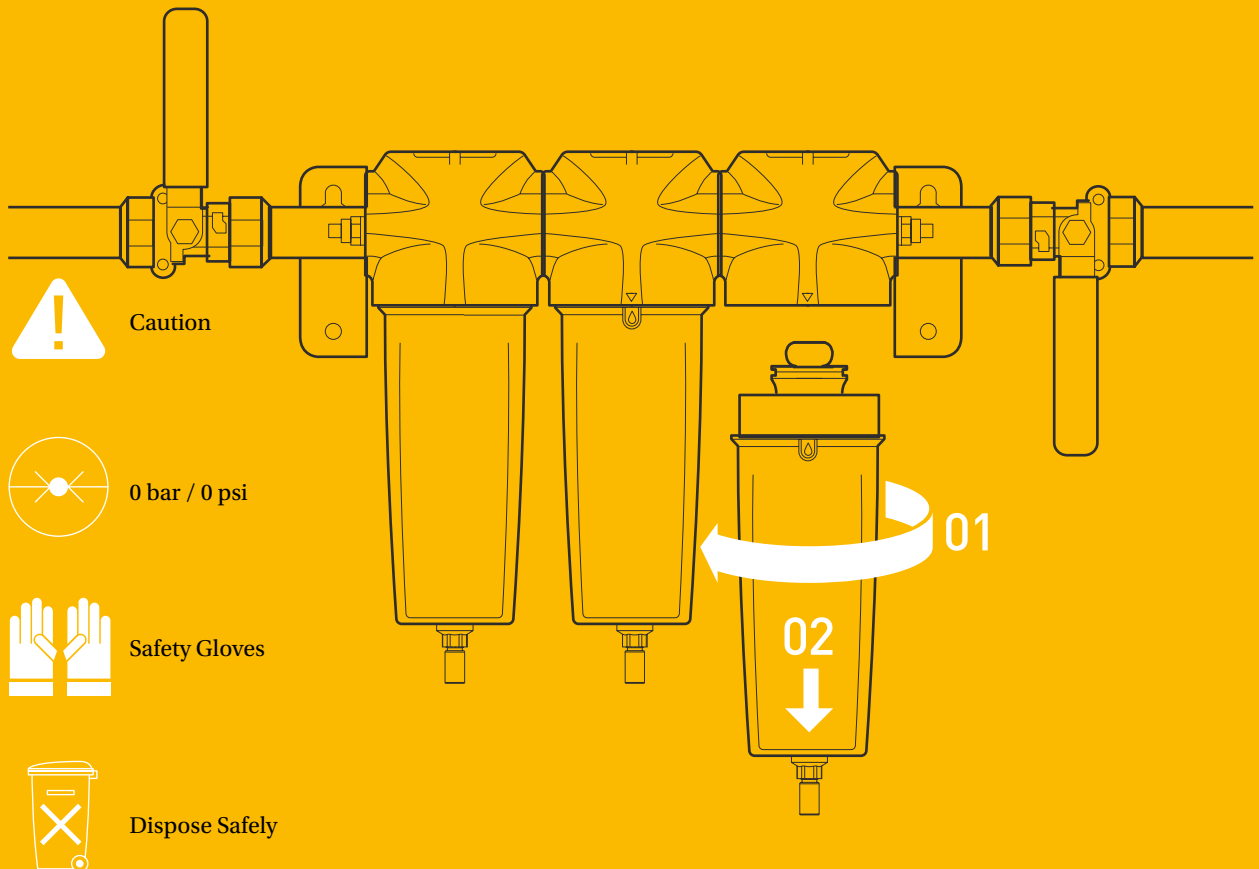

REMOVAL OF ELEMENT FROM FILTER BOWL

Remove the element from the filter bowl.

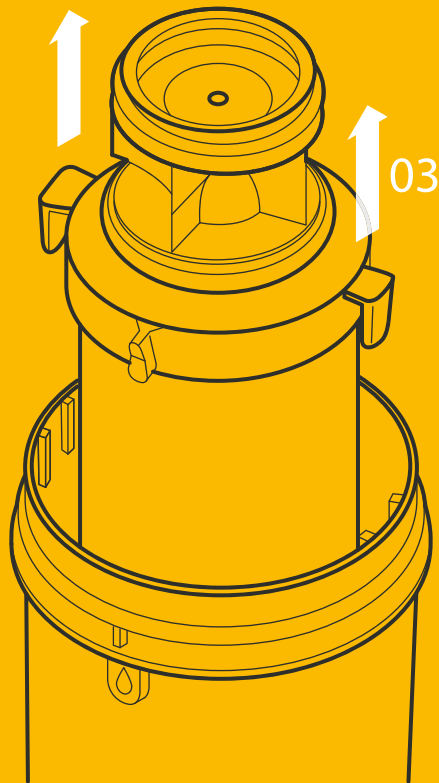

AUTOMATIC DRAIN REPLACEMENT

Unscrew the automatic drain (01) and discard (02). Fit the new drain (03) and tighten (04).

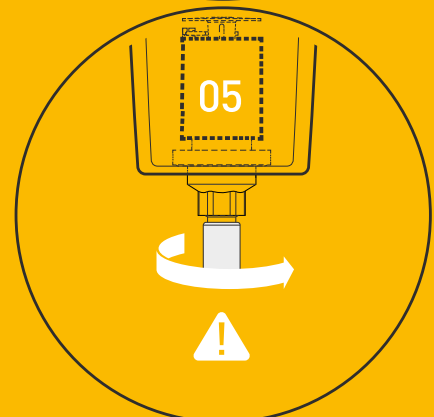
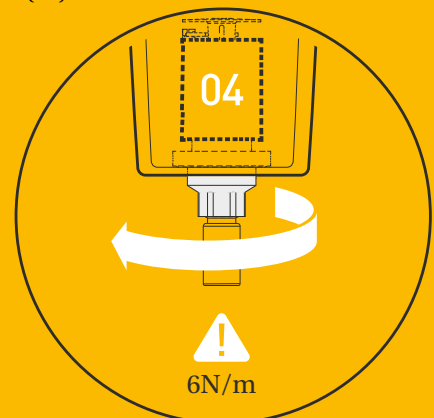

Dispose Safely

INSERTION OF REPLACEMENT ELEMENT INTO FILTER BOWL

Insert the new element into the filter bowl ensuring that the lugs are seated correctly in the grooves.

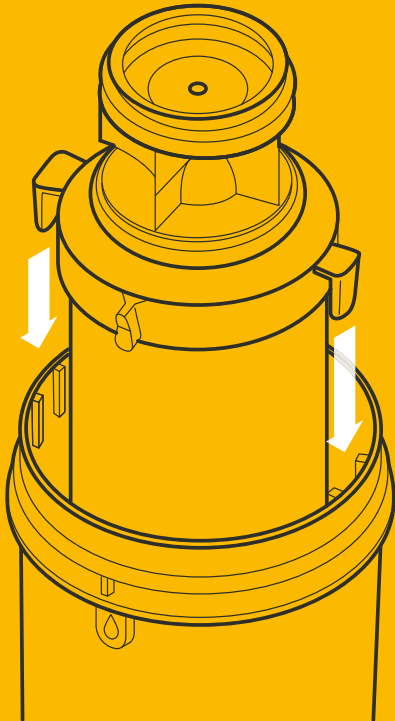

REPLACEMENT OF FILTER HEAD O RING SEAL

Replace the O-ring located in the filter head with the new O-ring provided.

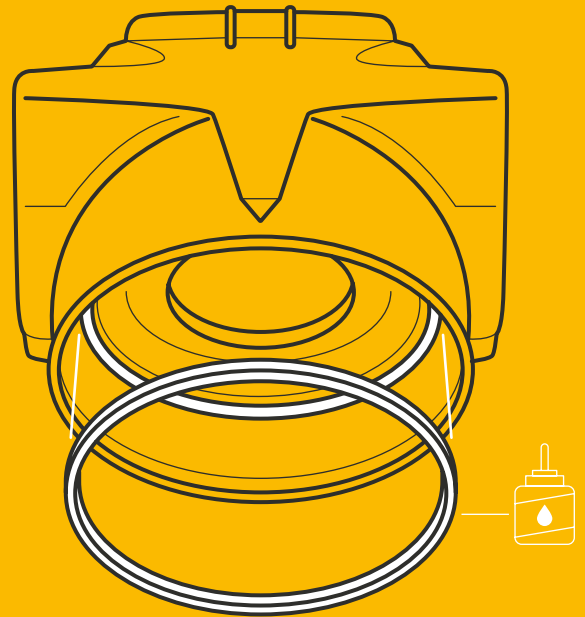

Ensure to lubricate the O-ring and threads with a suitable acid free Petroleum jelly.

RECONNECTING THE FILTER BOWL WITH HEAD

Refit the filter bowl and head ensuring that the threads are fully engaged (01) and the locking details are aligned (02).

Note: To ensure that the bowl is fully engaged into the head, the 010-030 bowl requires 360° of rotation until the thread stop, 720° for the 035-045 bowl and 540° for the 050-055 bowl.

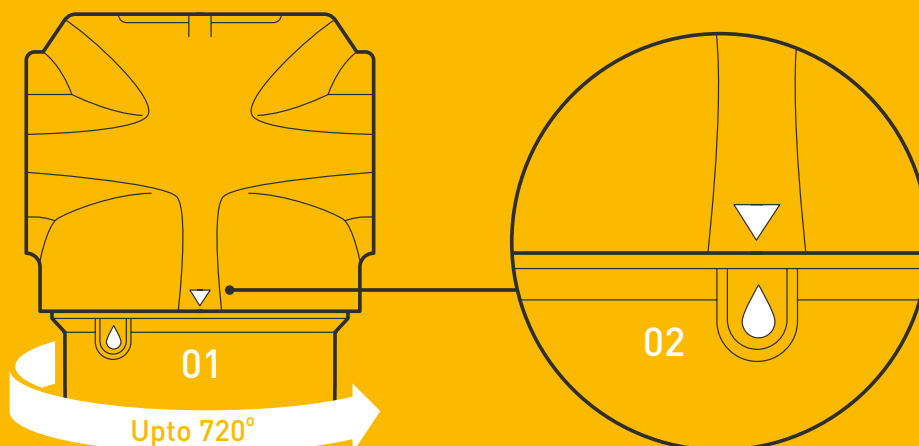

SERVICE REMINDER LABEL

Attach the element change date label to the filter bowl and write on the date the element is to be replaced. i.e 12 months after element change.



Do not use solvents or alcohol to clean the labels as this could cause damage.



0 bar / 0 psi

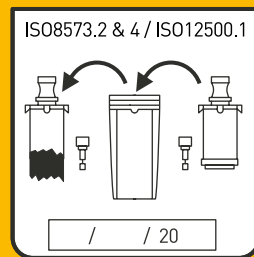

SYSTEM START UP PROCEDURE

Slowly open the inlet valve (01) to gradually pressurise the filter and wait 1 minute (02) before slowly opening the outlet valve (03) to re-pressurise the downstream piping.

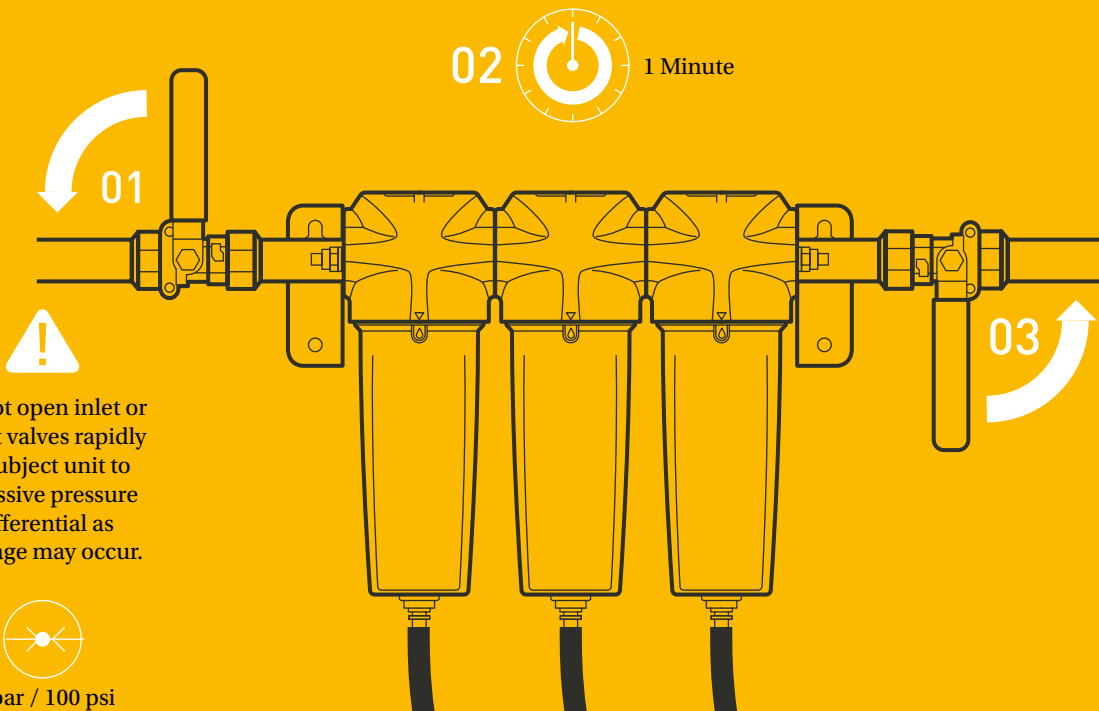

Do not open inlet or outlet valves rapidly or subject unit to excessive pressure differential as damage may occur.



7 bar / 100 psi

STILL STUCK? WATCH THE HOW-TO GUIDE



Watch this guide via [Parker Hannifin](#)

WHAT YOU'LL FIND IN THIS VIDEO

Installing the OIL-X System

Start-up Procedure

System De-pressurisation

Filter Bowl Removal

Removal of Element from Filter Bowl

Automatic Drain Replacement

Insertion of Replacement Element into Filter Bowl

Replacement of Filter Head O Ring Seal

Reconnecting the Filter Bowl with Head

Service Reminder Label

System Start-up Procedure

TECHNICAL SPECIFICATION

MODEL CODING EXAMPLE

PRODUCT SELECTION

Stated flows are for operation at 7 bar g (100 psi g) with reference to 20°C, 1 bar a, 0% relative water vapour pressure.

For flows at other pressures apply the correction factors shown.

MODEL						
ELEMENT GRADE	PREMIUM ENERGY EFFICIENT ELEMENT	MODEL SIZE	PORT SIZE	THREAD TYPE	DRAIN OPTION	DP INDICATOR
WS AO AA ACS	PX	3 digit code as shown below	A = 1/4" B = 3/8" C = 1/2" D = 3/4" E = 1" G = 1 1/2" H = 2" I = 2 1/2" J = 3"	G = BSPP N = NPT	F = Float M = Manual	X = None
AA	PX	030	A	G	F	X

WATER SEPARATOR FLOW RATES

MODEL		PORT SIZE	L/S	M ³ /MIN	M ³ /HR	CFM
WS	PX010A [] [] []	1/4	10	0.6	36	21
WS	PX010B [] [] []	3/8	10	0.6	36	21
WS	PX010C [] [] []	1/2	10	0.6	36	21
WS	PX015B [] [] []	3/8	40	2.4	144	85
WS	PX015C [] [] []	1/2	40	2.4	144	85
WS	PX020D [] [] []	3/4	40	2.4	144	85
WS	PX025D [] [] []	3/4	110	6.6	396	233
WS	PX025E [] [] []	1	110	6.6	396	233
WS	PX030G [] [] []	1 1/2	110	6.6	396	233
WS	PX035G [] [] []	1 1/2	350	21.0	1260	742
WS	PX040H [] [] []	2	350	21.0	1260	742
WS	PX045I [] [] []	2 1/2	350	21.0	1260	742
WS	PX050I [] [] []	2 1/2	800	48.0	2880	1695
WS	PX055J [] [] []	3	800	48.0	2880	1695

Product Selection & Correction Factors

To correctly select a separator model, the flow rate of the separator must be adjusted for the minimum operating (inlet) pressure at the point of installation.

1. Obtain the minimum operating (inlet) pressure and maximum compressed air flow rate at the inlet of the separator.
2. Select the correction factor for minimum inlet pressure from the CFMIP table (always round down e.g. for 5.3 bar, use 5 bar correction factor)
3. Calculate the minimum filtration capacity. Minimum Filtration Capacity = Compressed Air Flow Rate x CFP
4. Using the minimum filtration capacity, select a filter model from the flow rate tables above (filter selected must have a flow rate equal to or greater than the minimum filtration capacity).

CFMIP – Correction Factor Minimum Inlet Pressure (Water Separators)

Minimum Inlet Pressure	bar g	1	2	3	4	5	6	7	8	9	10	11	12	13	14	15	16
	psi g	15	29	44	58	73	87	100	116	131	145	160	174	189	203	218	232
Correction Factor		4.00	2.63	2.00	1.59	1.33	1.14	1.00	0.94	0.89	0.85	0.82	0.79	0.76	0.73	0.71	0.68

FILTER FLOW RATES

MODEL				PORT SIZE	L/S	M ³ /MIN	M ³ /HR	CFM	REPLACEMENT ELEMENT KIT		NO.	
[GRADE]	PX010A	[]	[]	[]	1/4	10	0.6	36	21	P010	[Grade]	1
[GRADE]	PX010B	[]	[]	[]	3/8	10	0.6	36	21	P010	[Grade]	1
[GRADE]	PX010C	[]	[]	[]	1/2	10	0.6	36	21	P010	[Grade]	1
[GRADE]	PX015B	[]	[]	[]	3/8	20	1.2	72	42	P015	[Grade]	1
[GRADE]	PX015C	[]	[]	[]	1/2	20	1.2	72	42	P015	[Grade]	1
[GRADE]	PX020C	[]	[]	[]	1/2	30	1.8	108	64	P020	[Grade]	1
[GRADE]	PX020D	[]	[]	[]	3/4	30	1.8	108	64	P020	[Grade]	1
[GRADE]	PX025D	[]	[]	[]	3/4	60	3.6	216	127	P025	[Grade]	1
[GRADE]	PX025E	[]	[]	[]	1	60	3.6	216	127	P025	[Grade]	1
[GRADE]	PX030E	[]	[]	[]	1	110	6.6	396	233	P030	[Grade]	1
[GRADE]	PX030G	[]	[]	[]	1 1/2	110	6.6	396	233	P030	[Grade]	1
[GRADE]	PX035G	[]	[]	[]	1 1/2	160	9.6	576	339	P035	[Grade]	1
[GRADE]	PX040H	[]	[]	[]	2	220	13.2	792	466	P040	[Grade]	1
[GRADE]	PX045H	[]	[]	[]	2	330	19.8	1188	699	P045	[Grade]	1
[GRADE]	PX045I	[]	[]	[]	2 1/2	330	19.8	1188	699	P045	[Grade]	1
[GRADE]	PX050I	[]	[]	[]	2 1/2	430	25.8	1548	911	P050	[Grade]	1
[GRADE]	PX055I	[]	[]	[]	2 1/2	620	37.3	2232	1314	P055	[Grade]	1
[GRADE]	PX055J	[]	[]	[]	3	620	37.3	2232	1314	P055	[Grade]	1

Product Selection & Correction Factors

To correctly select a filter model, the flow rate of the filter must be adjusted for the minimum operating (inlet) pressure at the point of installation.

1. Obtain the minimum operating (inlet) pressure and maximum compressed air flow rate at the inlet of the filter.
2. Select the correction factor for minimum inlet pressure from the CFMIP table (always round down e.g. for 5.3 bar, use 5 bar correction factor)
3. Calculate the minimum filtration capacity. Minimum Filtration Capacity = Compressed Air Flow Rate x CFMIP
4. Using the minimum filtration capacity, select a filter model from the flow rate tables above (filter selected must have a flow rate equal to or greater than the minimum filtration capacity).

CFMIP – Correction Factor Minimum Inlet Pressure (Coalescing and Dry Particulate Filters)

Minimum Inlet Pressure	bar g	1	2	3	4	5	6	7	8	9	10	11	12	13	14	15	16	17	18	19	20
	psi g	15	29	44	58	73	87	100	116	131	145	160	174	189	203	218	232	248	263	277	290
Correction Factor		4.00	2.63	2.00	1.59	1.33	1.14	1.00	0.94	0.89	0.85	0.82	0.79	0.76	0.73	0.71	0.68	0.64	0.62	0.61	0.59

TECHNICAL DATA

FILTRATION GRADE	FILTER MODELS	MIN OPERATING PRESSURE		MAX OPERATING PRESSURE		MIN RECOMMENDED OPERATING TEMP		MAX RECOMMENDED OPERATING TEMP	
		BAR G	PSI G	BAR G	PSI G	°C	°F	°C	°F
WS with float drain	PX010 to 055	1.5	22	16	232	2	35	65	149
AO with float drain	PX010 to 055	1.5	22	16	232	2	35	65	149
AO with manual drain	PX010 to 055	1	15	20	290	2	35	80	176
AA with float drain	PX010 to 055	1.5	22	16	232	2	35	65	149
AA with manual drain	PX010 to 055	1	15	20	290	2	35	80	176
ACS with manual drain	PX010 to 055	1	15	20	290	2	35	50	122

Note: AO / AA / WS grade filters for use up to 16 bar g (232 psi g) are supplied with a float drain [F] as standard. For pressures between 16 and 20 bar g (232 and 290 psi g) a manual drain [M] must be used. ACS grade filters are supplied with a manual drain [M] as standard.

WATER SEPARATOR WEIGHTS AND DIMENSIONS

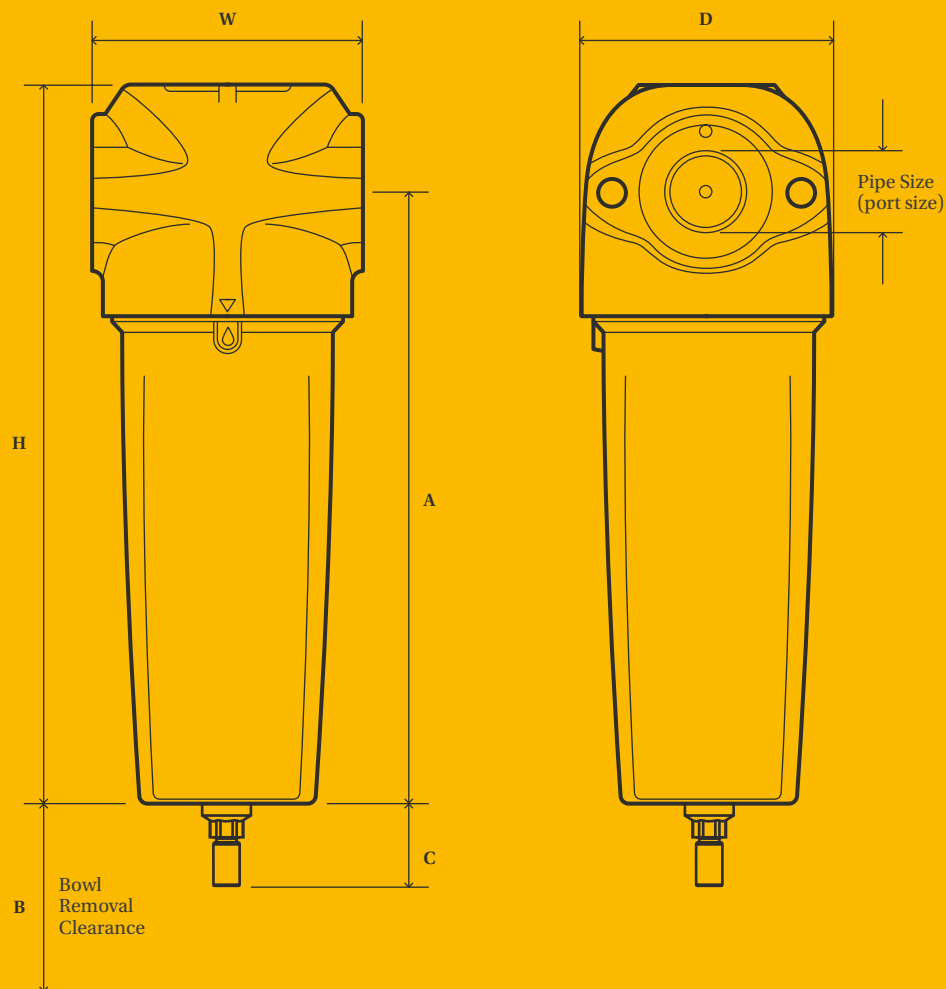

WATER SEPARATOR WEIGHTS AND DIMENSIONS

MODEL	PIPE SIZE	HEIGHT (H)		WIDTH (W)		DEPTH (D)		(A)		(B)		(C)		WEIGHT	
		MM	INS	MM	INS	MM	INS	MM	INS	MM	INS	MM	INS	KG	LBS
WSPX010A	1/4	180	7.09	76	2.99	65	2.56	154	6.06	50	1.97	30	1.18	0.81	1.78
WSPX010B	3/8	180	7.09	76	2.99	65	2.56	154	6.06	50	1.97	30	1.18	0.81	1.78
WSPX010C	1/2	180	7.09	76	2.99	65	2.56	154	6.06	50	1.97	30	1.18	0.81	1.78
WSPX015B	3/8	238	9.37	89	3.5	84	3.31	202	7.95	50	1.97	30	1.18	1.41	3.10
WSPX015C	1/2	238	9.37	89	3.5	84	3.31	202	7.95	50	1.97	30	1.18	1.41	3.10
WSPX020D	3/4	238	9.37	89	3.5	84	3.31	202	7.95	50	1.97	30	1.18	1.41	3.10
WSPX025D	3/4	277	10.91	120	4.72	115	4.53	232	9.13	70	2.76	30	1.18	2.66	5.86
WSPX025E	1	277	10.91	120	4.72	115	4.53	232	9.13	70	2.76	30	1.18	2.66	5.86
WSPX030G	1 1/2	277	10.91	120	4.72	115	4.53	232	9.13	70	2.76	30	1.18	2.66	5.86
WSPX035G	1 1/2	440	17.32	164	6.46	157	6.18	383	15.07	100	3.94	30	1.18	6.87	15.14
WSPX040H	2	440	17.32	164	6.46	157	6.18	383	15.07	100	3.94	30	1.18	6.87	15.14
WSPX045I	2 1/2	440	17.32	164	6.46	157	6.18	383	15.07	100	3.94	30	1.18	6.87	15.14
WSPX050I	2 1/2	514.5	20.26	192	7.56	183	7.20	542	21.33	120	4.72	32	1.25	8.47	18.66
WSPX055J	3	514.5	20.26	192	7.56	183	7.20	542	21.33	120	4.72	32	1.25	8.47	18.66

Note: Use dimension H + C for the total height.

FILTER WEIGHTS AND DIMENSIONS

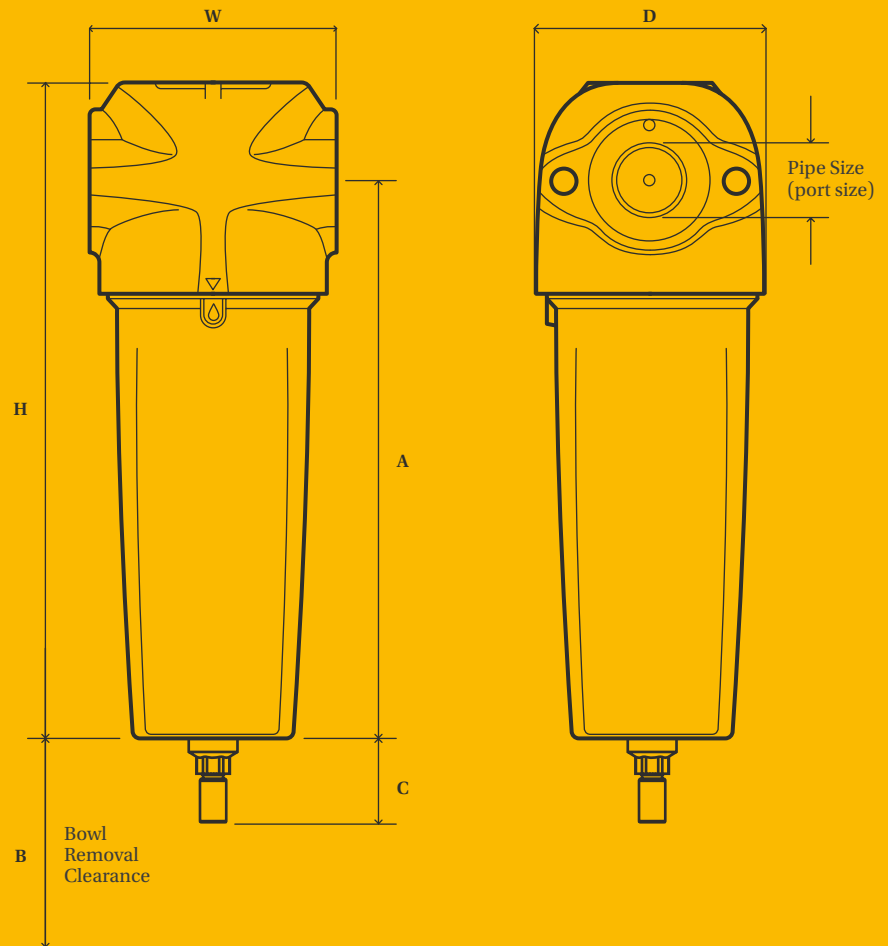

FILTER WEIGHTS AND DIMENSIONS

MODEL	PIPE SIZE	HEIGHT (H)		WIDTH (W)		DEPTH (D)		(A)		(B)		(C)		WEIGHT	
		MM	INS	MM	INS	MM	INS	MM	INS	MM	INS	MM	INS	KG	LBS
PX010A	1/4	180	7.09	76	2.99	65	2.56	154	6.06	50	1.97	30	1.18	0.81	1.78
PX010B	3/8	180	7.09	76	2.99	65	2.56	154	6.06	50	1.97	30	1.18	0.81	1.78
PX010C	1/2	180	7.09	76	2.99	65	2.56	154	6.06	50	1.97	30	1.18	0.81	1.78
PX015B	3/8	238	9.37	89	3.5	84	3.31	202	7.95	50	1.97	30	1.18	1.41	3.10
PX015C	1/2	238	9.37	89	3.5	84	3.31	202	7.95	50	1.97	30	1.18	1.41	3.10
PX020C	1/2	238	9.37	89	3.5	84	3.31	202	7.95	50	1.97	30	1.18	1.41	3.10
PX020D	3/4	238	9.37	89	3.5	84	3.31	202	7.95	50	1.97	30	1.18	1.41	3.10
PX025D	3/4	277	10.91	120	4.72	115	4.53	232	9.13	70	2.76	30	1.18	2.66	5.86
PX025E	1	277	10.91	120	4.72	115	4.53	232	9.13	70	2.76	30	1.18	2.66	5.86
PX030E	1	367	14.45	120	4.72	115	4.53	322	12.68	70	2.76	30	1.18	3.01	6.63
PX030G	1 1/2	367	14.45	120	4.72	115	4.53	322	12.68	70	2.76	30	1.18	3.01	6.63
PX035G	1 1/2	440	17.32	164	6.46	157	6.18	383	15.07	100	3.94	30	1.18	6.87	15.14
PX040H	2	532	20.94	164	6.46	157	6.18	475	18.7	100	3.94	30	1.18	7.18	15.82
PX045H	2	532	20.94	164	6.46	157	6.18	475	18.7	100	3.94	30	1.18	7.18	15.82
PX045I	2 1/2	532	20.94	164	6.46	157	6.18	475	18.7	100	3.94	30	1.18	7.18	15.82
PX050I	2 1/2	654	25.75	192	7.56	183	7.20	582	22.91	120	4.72	32	1.25	10.18	22.43
PX055I	2 1/2	844	33.23	192	7.56	183	7.20	772	30.39	120	4.72	32	1.25	15.78	34.78
PX055J	3	844	33.23	192	7.56	183	7.20	772	30.39	120	4.72	32	1.25	15.78	34.78

ACCESSORIES / SPARE PARTS (SERVICE KITS)

FILTER MODELS	CAT NO.	CONTENTS			
010	TRK1-2				
015 - 020	TRK2-2				
025 - 030	TRK3-2				
035 - 045	TRK4-2				
050 - 055	TRK5-2				
010	MBK1-1				
015 - 020	MBK2-1				
025 - 030	MBK3-1				
035 - 045	MBK4-1				
050 - 055	MBK5-1				
010	MBK1-2				
015 - 020	MBK2-2				
025 - 030	MBK3-2				
035 - 045	MBK4-2				
050 - 055	MBK5-2				
010 - 055	EM1		010 - 055	M12.FD.0001	

EU Declaration of Conformity

EN

Parker Hannifin Manufacturing Limited GSFE
Dukesway, Team Valley Trading Estate, Gateshead, Tyne & Wear, NE11 0PZ, UK
Compressed Air Filter / Water Separator

Oil-X AOP / AOPX / AAP / AAPX / ACSP / ACSPX / WSP / WSPX 010 - 055

PED 2014/68/EU

Directives

PED Generally in accordance with ASME VIII Div 1 : 2015

Standards used

PED Assessment Route: Art.4 Para.3 (SEP) (010 - 030)
Module B + D (035 - 055)

PED Certificate Number 50351

Notified body for PED: Notified Body Number: 0525
LRQA Deutschland GmbH
Curienstraße 1,
D-20095 Hamburg, Deutschland

Authorised Representative Steven Rohan
Division Engineering Manager,
Parker Hannifin Manufacturing Limited GSFE

Declaration

This declaration of conformity issued under the sole responsibility of the manufacturer and the essential safety requirements have been demonstrated and fulfilled as set out in Annex 1

Signature:



Date: 01 December 2023

Declaration Number:
00298 / 1.12.23

PARKER WORLDWIDE

AE – UAE, Dubai
Tel: +971 4 8127100
parker.me@parker.com

AR – ARGENTINA, Buenos Aires
Tel: +54 3327 44 4129

AT – AUSTRIA, Wiener Neustadt
Tel: +43 (0)2622 23501-0
parker.austria@parker.com

AT – EASTERN EUROPE, Wiener Neustadt
Tel: +43 (0)2622 23501 900
parker.easteurope@parker.com

AU – AUSTRALIA, Castle Hill
Tel: +61 (0)2-9634 7777

AZ – AZERBAIJAN, Baku
Tel: +994 50 2233 458
parker.azerbaijan@parker.com

BE/LU – BELGIUM, Nivelles
Tel: +32 (0)67 280 900
parker.belgium@parker.com

BR – BRAZIL, Cachoeirinha RS
Tel: +55 51 3470 9144

BY – BELARUS, MINSK
Tel: +375 17 209 9399
parker.belarus@parker.com

CA – CANADA, Milton, Ontario
Tel: +1 905 693 3000

CH – SWITZERLAND, Etoy
Tel: +41 (0)21 821 87 00
parker.switzerland@parker.com

CL – CHILE, Santiago
Tel: +56 2 623 1216

CN – CHINA, Shanghai
Tel: +86 21 2899 5000

CZ – CZECH REPUBLIC, Klecany
Tel: +420 284 083 111
parker.czechrepublic@parker.com

DE – GERMANY, Kaarst
Tel: +49 (0)2131 4016 0
parker.germany@parker.com

DK – DENMARK, Ballerup
Tel: +45 43 56 04 00
parker.denmark@parker.com

ES – SPAIN, Madrid
Tel: +34 902 330 001
parker.spain@parker.com

FI – FINLAND, Vantaa
Tel: +358 (0)20 753 2500
parker.fi nland@parker.com

FR – FRANCE, Contamine s/Arve
Tel: +33 (0)4 50 25 80 25
parker.france@parker.com

GR – GREECE, Athens
Tel: +30 210 933 6450
parker.greece@parker.com

HK – Hong Kong
Tel: +852 2428 8008

HU – HUNGARY, Budapest
Tel: +36 1 220 4155
parker.hungary@parker.com

IE – IRELAND, Dublin
Tel: +353 (0)1 466 6370
parker.ireland@parker.com

IN – INDIA, Mumbai
Tel: +91 22 6513 7081-85

IT – ITALY, Corsico (MI)
Tel: +39 02 45 19 21
parker.italy@parker.com

JP – JAPAN, Tokyo
Tel: +81 (0)3 6408 3901

KR – SOUTH KOREA, Seoul
Tel: +82 2 559 0400

KZ – KAZAKHSTAN, Almaty
Tel: +7 7272 505 800
parker.easteurope@parker.com

LV – LATVIA, Riga
Tel: +371 6 745 2601
parker.latvia@parker.com

MX – MEXICO, Apodaca
Tel: +52 81 8156 6000

MY – MALAYSIA, Shah Alam
Tel: +60 3 7849 0800

NL – The Netherlands, Oldenzaal
Tel: +31 (0)541 585 000
parker.nl@parker.com

NO – NORWAY, Asker
Tel: +47 66 75 34 00
parker.norway@parker.com

NZ – NEW ZEALAND, Mt Wellington
Tel: +64 9 574 1744

PL – POLAND, Warsaw
Tel: +48 (0)22 573 24 00
parker.poland@parker.com

PT – PORTUGAL, Leca da Palmeira
Tel: +351 22 999 7360
parker.portugal@parker.com

RO – ROMANIA, Bucharest
Tel: +40 21 252 1382
parker.romania@parker.com

RU – RUSSIA, Moscow
Tel: +7 495 645-2156
parker.russia@parker.com

SE – SWEDEN, Spånga
Tel: +46 (0)8 59 79 50 00
parker.sweden@parker.com

SG – Singapore
Tel: +65 6887 6300

SK – SLOVAKIA, Banská Bystrica
Tel: +421 484 162 252
parker.slovakia@parker.com

SL – SLOVENIA, Novo Mesto
Tel: +386 7 337 6650
parker.slovenia@parker.com

TH – THAILAND, Bangkok
Tel: +662 717 8140

TR – TURKEY, Istanbul
Tel: +90 216 4997081
parker.turkey@parker.com

TW – TAIWAN, Taipei
Tel: +886 2 2298 8987

UA – UKRAINE, Kiev
Tel +380 44 494 2731
parker.ukraine@parker.com

UK – UNITED KINGDOM, Warwick
Tel: +44 (0)1926 317 878
parker.uk@parker.com

US – USA, Cleveland
Tel: +1 216 896 3000

VE – VENEZUELA, Caracas
Tel: +58 212 238 5422

ZA – SOUTH AFRICA, Kempton Park
Tel: +27 (0)11 961 0700
parker.southafrica@parker.com

European Product Information Centre

Free phone: 00 800 27 27 5374

(from AT, BE, CH, CZ, DE, EE, ES, FI, FR, IE, IL, IS, IT, LU, MT, NL, NO, PT, SE, SK, UK)

ONE YEAR AIR QUALITY GUARANTEE

Your air quality has been guaranteed for 1 year and will be renewed at every annual filter element change.

Annual filter element changes ensure:

- Optimal performance is maintained
- Air quality continues to meet international standards
- Protection of downstream equipment, personnel and processes
- Low operational costs
- Increased productivity and profitability
- Peace of mind

PARKER HANNIFIN MANUFACTURING LIMITED

Gas Separation and Filtration Division EMEA
Dukesway, Team Valley Trading Est
Gateshead, Tyne and Wear
England NE11 0PZ

Tel: +44 (0) 191 402 9000

Fax: +44 (0) 191 482 6296

www.parker.com/gsfe

