

# ELRO Peristaltic Pumps

## Series M300



ELRO M300 series Peristaltic Pumps were designed for safe, quick and mobile applications in the most varied industrial operating conditions. Over many years this unique, patented pump system has been and is successfully used world-wide for more and more new applications.

The basic idea during the development of the mobile peristaltic pumps was to integrate the advantages of standard peristaltic pumps and to achieve a compact, portable and flexible design. This idea was realised through a special, patented concept in the pump housing design.

Type / drive	Weight
<b>M 5 E(X) – M 20 E(X)</b> Electric motor 230-400 V + EX	55-65 kg 121-143 lb
<b>M 15 / 7,5 E(X) – M 20 / 10 E(X)</b> Two-stage electric motor 400 V + EX	62-65 kg 136-143 lb
<b>M 20 B</b> Petrol engine 4,0 kW / 4000 rpm 5.4 HP	52 kg 115 lb
<b>M 20 D</b> Diesel engine 4,15 kW / 3600 rpm 5.6 HP	75 kg 165 lb
<b>M 20 H</b> Hydraulic drive <b>M 20 L</b> Pneumatic motor <b>M 20 WT</b> Water turbine <b>M 20 FU</b> Electric motor with integrated frequency converter	55 kg/121 lb 58 kg/128 lb 56 kg/123 lb 66 kg/145 lb

It enables the use of thin-walled pumping hoses which are continuously expanded to their full cross-section by the permanent vacuum. Pumping capacities between 4 m<sup>3</sup>/h and 22 m<sup>3</sup>/h (17.6 - 97 USGPM) can be achieved.

Examples of application: Emergency pump on ships, sanitary disposal unit for fast trains, loading pump for road tankers, at power stations and sewage plants for sampling and for cleaning tanks and basins, in the chemical industry, for fluid transfer duties.

These pumps prefer a long suction line up to the absolute vacuum whereby suction lengths of more than 50 m (164 feet) are frequently used.

The discharge pressure should not exceed 2 bar (29 psi).

### Main Application:

- Environmental technology
- Tank cleaning
- Building industry
- Chemical industry
- Forwarders
- Power stations, disposal technology
- Ships, port facilities and skimmer

# Applications



Forwarders

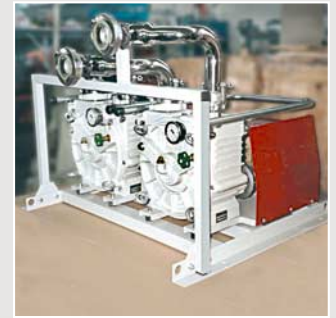

Environmental technology



Disposal technology



Galvanic station



Disposal fast trains

The peristaltic pumps can be equipped with different hose materials depending on applications as well as with couplings on the suction and discharge side in different materials and designs.

The M300 series can be selected with a variety of different motors.

For special applications, the pump is also available in a reversible design. Therefore it is possible to pump in the opposite direction with the same performance features - a decisive criterion when pumping out and pumping over media which are harmful to the environment.

The design of all pumps enables changing of pumping hose and all components within shortest period of time without any additional special tools.

### Dimensions (mm)

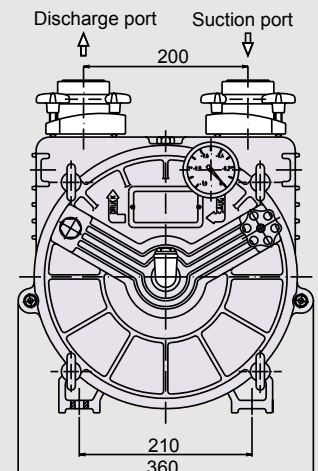
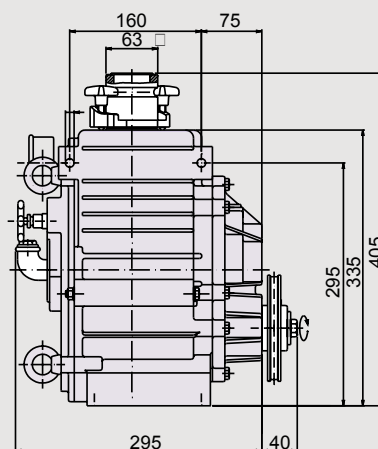

# ELRO Peristaltic Pumps

## Series M300

ELRO Peristaltic Pumps are available with a variety of accessories suitable for each specific application.

- 1 KL quick release couplings, pipe elbows, Storz couplings made of aluminium, brass or stainless steel, plastic, DIN, tank vehicle couplings made of brass or stainless steel.
- 2 Pulsation dampers made of aluminium and stainless steel with suitable T-piece.
- 3 Suction/discharge hoses are available with nominal size between 1" and 4" and equipped with suitable coupling systems completely pressure-tested.
- 4 70 litre (18.4 USGAL) pre-filter vessel made of steel and stainless steel with filling equipment
- 5 180 litre (47.5 USGAL) transport drum made of stainless steel with filling equipment
- 6 Hose cleaning device and balls in different designs.
- 7 Suction baskets, flat vacuum pick-ups, special suction pipes and residue suction nozzles made of different materials.

### Discharge Side Accessories

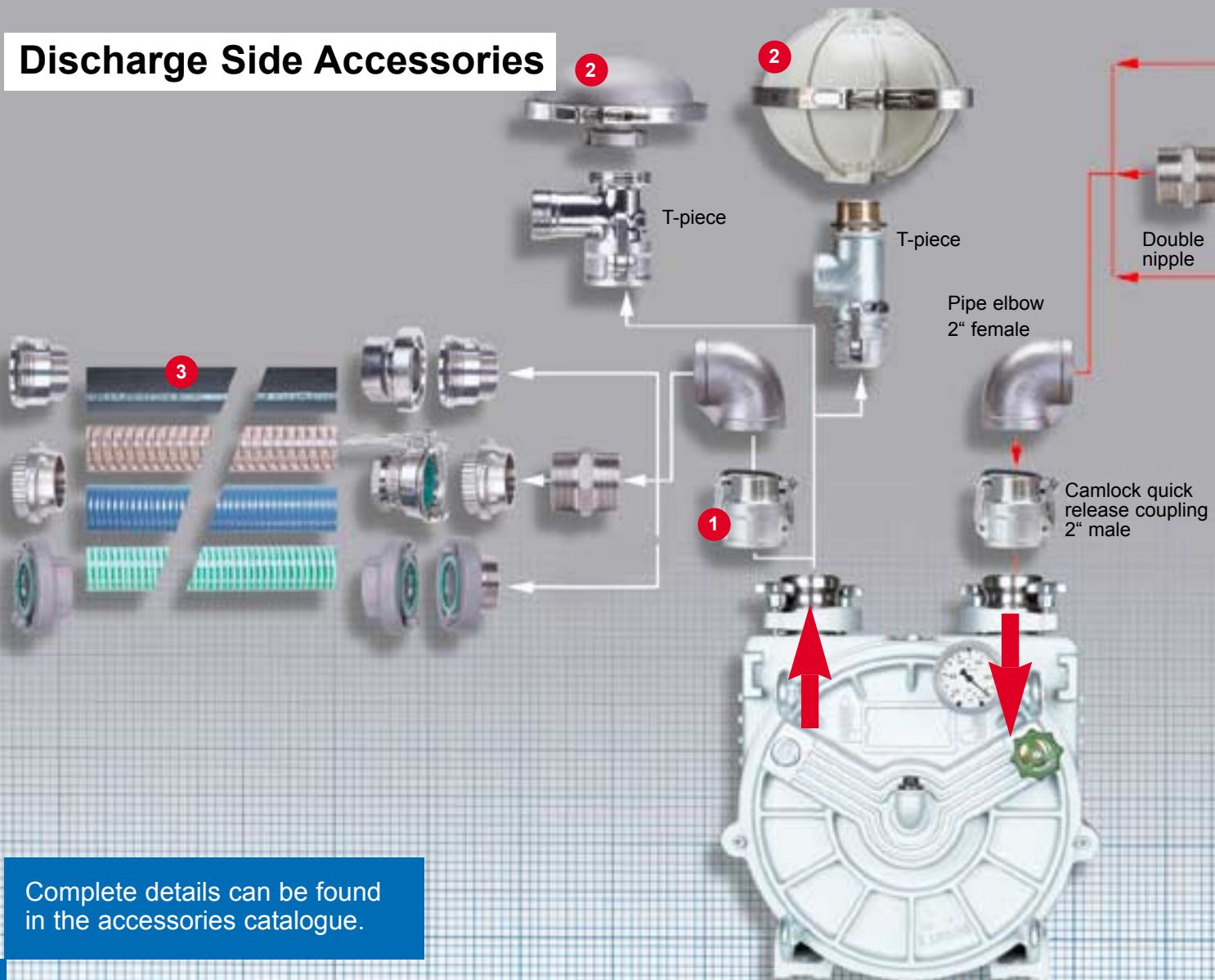

Complete details can be found in the accessories catalogue.

## Pump coding

**M 05 A B - E B -**

Model	Type m <sup>3</sup> /h	USGPm	Connections	Hose / lubricant	Paint finish	Base frame	Motor type	Motor
M	05 5	22	A Aluminium	B NBR+silicon	- Silver	E Fire brigade carrying frame stainless steel	B Petrol	- without
	07 7	31	K Polypropylene	C CSM + silicon	H Acidproof paint	F Fire brigade carrying frame galvanised steel	D Diesel	D EEx d T4
	10 10	44	R Brass	D NBR + glycerine	Z Customer-specific	T Aluminium (Standard)	E Electric	E EEx e T3
	11 10/5	44/22	S Stainless steel	G NR + glycerine		M Vehicle stainless steel	H Hydraulic	F Faryman
	15 15	66		H CSM + glycerine			L Pneumatic motor	H Honda
	17 15/7	66/31		J IIR + silicon			R Reversible	R Reversible
	20 20	88		K IIR + glycerine			W Water turbine	Y Yanmar
	21 20/10	88/44		N NR + silicon				Z Hatz
	OM Without Motor			P PUR + silicon				
				R PUR + glycerine				

## Suction Side Accessories

## Option

